



Long Life Reliability  
does not cost the earth

**Connection  
Systems**



**RED BOX  
AVIATION**

# **RB85 TWIN MANUAL**

**LPA Connection Systems**

**Light & Power House, Saffron Walden, Essex, CB11 3AQ, UK**

**TEL: +44 (0)1799 512800 Email: [enquiries@lpa-connect.com](mailto:enquiries@lpa-connect.com)**

**Website: [www.redboxaviation.com](http://www.redboxaviation.com) [www.lpa-group.com](http://www.lpa-group.com)**

LPA Industries reserves the right to amend or modify any designs or specifications in this document without prior notice, in order to incorporate technical developments or any relevant information.

## **12/24 VOLT POWER PACK RB85A**

### **INDEX**

	Page Number
Health & Safety Information / Before Use	1
Pack Layout / General Advice	2
Operational Procedure / Charge Status	3
Points on state of charge / Recharging	4
Care and Maintenance / Troubleshooting	5
Safety Instructions	6
Instructions for the charging point	7

### **IMPORTANT: - HEALTH AND SAFETY - See page 6 for further data.**

These portable power packs are designed to deliver very high instant DC power for short periods. They are extremely powerful, using military aerospace technology. They should only be used by personnel who have received instruction on the correct operating procedures. Failure to follow the correct procedures or to take adequate precautions could cause damage to electrical systems, result in injury to the operator, or damage the equipment.

### **WARNING - BEFORE USE**

Please take time to read, note and understand all the enclosed Operating Procedures and Safety Information, to ensure all users of the equipment are made fully aware of these instructions. Further information is on the side of the pack and details on charging are enclosed on a separate card for display at the charging station. Further Health and Safety information is on page 6. If after studying this manual there are any points or queries you would like to raise. Please contact the technical department at LPA Connection System.

### **CHECK LIST**

Standard packing list (recommended you store packaging).

1 off - Power Pack (RB60 and RB85)

1 off - Electronically controlled DC Voltage Charger

1 off - Aircraft Lead with 3Pin NATO Aircraft connector OR Croc clip lead set

1 off – Carry bag (RB25A Only)

1 off - Instructions Manual and Charging Station Card

Other connection leads (Available to order)

**\*Each system has been tested before dispatch and is serial numbered, (please record).**

**\*Please ensure the charger is fitted with suitable AC mains plug - If not see page 6**

### **BEFORE USE.**

**WHEN YOU RECEIVE THE GPU, PLEASE FULLY CHARGE FOR MINIMUM 24 HOURS**

FOR BEST SERVICE LIFE PLEASE READ THE SEPARATE CHARGING INFORMATION AND PLEASE ENSURE THESE ARE DISPLAYED AT THE CHARGING STATION.

AFTER CARRYING OUT 2 OR 3 STARTS, WITH FULL CHARGING IN BETWEEN, THE CELLS WILL BE FULLY EXERCISED AND AT THE OPTIMUM

## **GENERAL ADVICE**

The pack and the charger are tested and checked before they are shipped to you.

The pack is essentially dry (no free liquid) and can be transported or operated in any position, safely by Land, Sea or Air. Packs must be transported with the isolator in the off position. The Safety Clearance for Air transportation is in accordance with: -CAA. Ref. 10A/211/12 in association with ICAO Special provision A67

Please note that this power pack utilises special batteries that are specially designed to give out very high power - they are similar to Aircraft Batteries.

To get the best performance from them, it is essential that you keep them charged as fully as possible, especially when starting large engines.

These batteries are not like Ni Cad types. They DO NOT have a memory and they do not need to be cycled. They can and should be put back on the charger as soon as possible after they have been used to start an engine.

Keep the pack charged up high. If possible, keep the pack permanently on charge.

STORAGE - The unit can be stored for long periods of time with very low self-discharge. If storing for a long period of time, (one month or more) fully charge the unit for 24hours. Exact self-discharge is temperature dependent. Details are available on request. NEVER leave the pack for any period in a fully discharged state. Always recharge as soon as possible for best life.

**WARNING** - Do not short circuit. Switch off and remove key and cables when not in use or connected to an aircraft or other vehicle.

### **For Twin RB85A use:**

**Please ensure when using the Twin system that both keys are turned on before operation.**

**NB: When on key is turned on both LED display panels will illuminate, however this does not mean that both packs are turned on.**

## Using a standard Aircraft Lead

1. Check charge status. (see below)
2. Ensure Pack is Switched **OFF**.
3. Select voltage by plugging in the Flying lead.
4. Plug cable into aircraft.
5. Plug cable into power pack **-If audible buzzer sounds disconnect cables and check polarities.**
6. Switch pack **ON** when instructed by cockpit controller -CHECK voltage readout in cockpit.  
**RESPONSIBILITY FOR OPERATION REMAINS IN THE COCKPIT AT ALL TIMES**
7. Start engine as required.
8. Switch **OFF** pack (Check with cockpit first). Then Disconnect from aircraft.

## If "Jump Clip" Crocodile type leads are being used -

1. Check charge status. (see below)
2. Ensure pack is switched **OFF**.
3. Select voltage by plugging in the Flying lead.
4. **FIRST verify the Positive and Negative terminals.** Only then place jump leads on battery terminals,
5. Insert plug into pack-.
6. IF WARNING **BUZZER SOUNDS DO NOT SWITCH ON** until you are sure that the system wiring is correct.  
**Even if warning buzzer does not sound - Double check polarity is correct.**
7. If connections are correct, switch **ON** power pack.
8. Start Engine as required.
9. Run engine to charge onboard battery.
10. Switch **OFF** power pack (check with cockpit first) then disconnect from aircraft or vehicle.  
**Put GPU on charger as soon as possible to give best operational life.**

**NOTE if regularly recharged from an aircraft the power pack should be FULLY recharged from the charger supplied every 2 weeks or so.**

## **CHARGE STATUS**

The charge status of the pack can be obtained by reading the value from the digital voltmeter.

The voltage shown is proportional to the level of charge in the pack. It is not an indication of the capacity of the pack.

- Disconnect all leads from the pack.
- Switch on the pack and read the voltage.

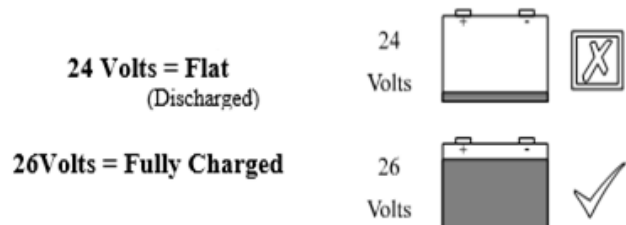

## **NEVER discharge below FLAT**

### **NOTE:**

- The power pack should be kept on the charger at least until the float light shows. If possible, the power pack should be left permanently on the charger supplied.

**Operational Capacity of the unit MUST always be determined by the operator before use.**

## Important Points on State of Charge

State of charge is not a measurement of the CAPACITY of the battery.

With a multistage charging system, when the charger switches to FLOAT the pack is approx. 90% charged. This can be used as a guide - If the charger is in Float mode, the pack must be more than 90% charged.

## RECHARGING.

- Plug the connectors on the spliced mains lead into each charger.
- Connect the charger to a SUITABLE voltage AC 50 or 60Hz inlet - 100 – 230 Volts Switch ON AC supply
- Switch ON the charger.
- Leave the pack on the charger until the **green light (Full) shows** - This is about 90% charged.
- If possible leave the pack connected to the charger to fully (100%) charge. This may take several hours

**The Charger may only be left connected WITH THE MAINS POWER ON  
for extended periods of time.**

**No damage will occur - This is good for the health of the pack**

- To disconnect - Switch OFF the charger and AC supply.
- Unplug the charger lead from the AC supply and remove the leads to the pack.

When in regular use, recharge for a continuous 24-Hour period  
(Every 2 - Weeks)

## Points on Recharging

- **Do not** leave the chargers connected to the pack and **NOT SWITCHED ON.**
- Use the voltage-controlled chargers supplied by LPA. It is specifically set for these cells.
- **NEVER** start or crank an engine with the charger connected.
- Ensure a good quality electricity supply. If you are operating in a country with electrical inconsistencies install a power conditioner to give clean regulated power.
- The pack can be recharged from an Aircraft or Vehicle with a suitable interface, at the operators' discretion - Please contact LPA for further information.
- There is no memory effect with these types of cell, as with Ni Cads. They can be recharged at anytime. Cycling is not required, so recharge as soon as possible.
- The power pack can be switched on whilst on charge.
- If, for any reason, **the pack becomes discharged below 24 volts (in 24V mode) or 12 volts (in 12V mode) (other than when starting) – It must be put back on charge immediately and left on charge continuously for a period of 24 Hours**

**Consistently UNDERCHARGING the pack can lead to lower performance and life.**

## CARE & MAINTENANCE

NEVER expose the pack to extremes of temperature. Do not leave in **direct Sun**. In EXTREME COLD take the pack with you and keep it warm until ready for use.

The power pack does not need maintenance during its life, other than charging.

When the internal cells finally need replacing, call LPA or agent for Service.

## TROUBLE SHOOTING

The diagram and table below can be used to find faults. If there is ever any doubt, contact a Qualified Electrical Engineer. If the unit does not charge. - Check that the Mains supply to the chargers is healthy and the Circuit Breakers on the pack haven't tripped. Any queries consult LPA for advice.

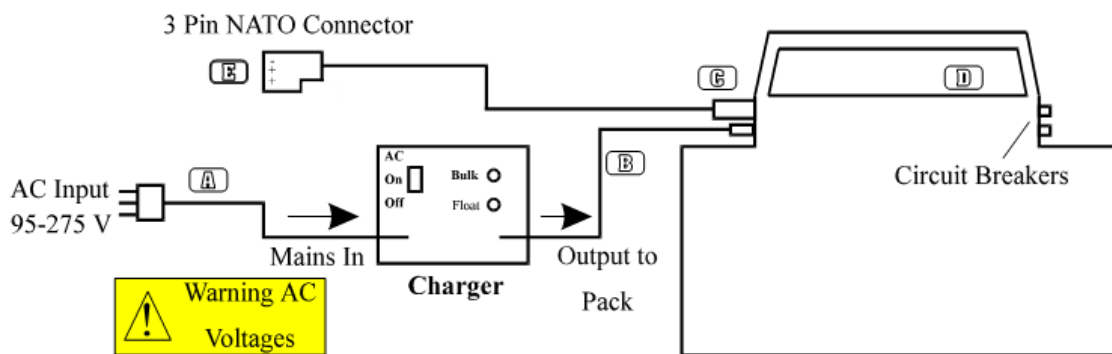

**With a suitable Voltmeter check the voltages at the points shown.**

Any doubt - Contact a Qualified Electrical Engineer.

All the values in the table assume the pack and charger are switched on and the pack is fully charged.

FAULT		A	B	C	D	E		
<u>Without Charger</u>								
No Output		-	-	0	0	0	Internal Wiring Fault	*
		-	-	0	28	0	Internal Wiring Fault	*
		-	-	2	28	0	Output lead Failure	A
<u>With Charger Connected</u>								
No Charging	Bulk	110-230	0	0	0	0	Internal Charger Fault	B
	Bulk	110-230	28	28	28	28	Reset Circuit breakers	C
	Floa	110-230	0	0	0	0	Internal Charger Fault	B
	t							
	Floa	110-230	28	28	28	28	Reset Circuit breakers	C
t								

If the unit is not fully charged different values will appear. - Please contact Red Box for advice

- Check Output lead for breaks or damage. Check connections in NATO especially 3<sup>rd</sup> Pin.
- Internal Charger Fault Ensure RED mains on switch are illuminated. If not check supply - Disconnect charger from AC. - With charger connected to pack the green Float LED should illuminate. If not, check the connection of the charger plug.
- Power is flowing from the charger to the pack, but not charging the cells - Reset circuit breaker. (Push In)

**IMPORTANT: HEALTH AND SAFETY AT WORK CAUTION.**

These portable power packs are designed to deliver very high instant DC power for short periods. They are extremely powerful, using military aerospace technology. They should only be used by personnel who have received instruction on the correct operating procedures. Failure to follow the correct procedures or to take adequate precautions could cause damage to electrical systems, result in injury to the operator, or damage to equipment.

### **BEFORE USE**

Read, note and understand the operating procedures, GUIDANCE NOTES AND MANUALS and ensure all users of the equipment are made fully aware of these instructions **ALSO** read the instructions on the side of the pack.

### **SAFETY**

1. When not being used, always disconnect removable cables from the power pack.
2. Never short-circuit the equipment - check that onboard battery terminals or bare leads etc. Are not touching the aircraft or vehicle.
3. Always use **extreme caution** when connecting to other batteries (Jump Starting) SEE that the **Voltage AND polarities are correct. Always double check.**
4. Never under any circumstances, boost charge the power pack.
5. Use only the charger supplied by LPA. It is set and regulated to maximize battery life and is designed so that it cannot overcharge.

### **IMPORTANT**

#### **When using or charging the pack REMEMBER**

- **NEVER** Boost charge - cells will be destroyed.
- **NEVER** Leave pack in a discharged state - recharge as soon as possible.
- **NEVER** Try to use the isolator key as a starter switch.
- **NEVER** Try to start an aircraft with either a seized engine or shorted starter motor.
- **NEVER** Start with charger connected.

### **TRANSPORTATION**

**NEVER** - Transport the pack in an aircraft unless it is securely tied down and Fly lead is disconnected.

### **CHARGER SAFETY**

The charger is manufactured in the UK to BS standards and therefore has the following colours of wire on the input lead:

**The wire coloured BLUE is NEUTRAL**

**The wire coloured BROWN is LIVE**

**The wire coloured GREEN/YELLOW is Earth.**

- The appliance must be earthed.
- RE Charger is for indoor use only - **DO NOT** expose to rain or excessive moisture.
- If the fuse fails in the appliance, it must be replaced with a fuse of the same value.
- There are no user-serviceable parts in the charger.
- Do NOT open - There is Very High Power inside.

### **WEIGHT**

- The power pack is heavy - handle with care.

# **1-YEAR WARRANTY**

## Limited warranty and limitation of liability (Including limitation of consequential damages)

- (a) LPA Industries Ltd (Seller) warrants that the goods are free from defects in seller's materials and workmanship.
- (b) The warranty set forth in (a) above (the "Warranty") shall apply only in favor of the buyer and shall expire on the last day of a period of One Year commencing on the date of delivery of the goods from seller to buyer.
- (c) The Warranty is expressly made subject to the following provisions:
  1. The Warranty shall not apply to any goods which have been repaired or altered or opened by anyone other than the seller, or *his assigns*, in any way so as, in the seller's judgment, to affect stability, reliability or performance nor to any goods which have been subjected to unreasonable use, negligence or accident, nor specifically to the capacity of batteries save where this relates to defect in seller's materials or workmanship, nor to any goods which have not been used in accordance with seller's printed instructions, nor to any goods which have been damaged because of their use or the use of any other materials or equipment.
  2. The extent of the seller's liability for any breach of the Warranty shall be limited to repairing or replacing (whichever of the two, seller, in his own discretion, shall elect) any defects in goods attributable to seller's workmanship or materials, by the seller, at the risk and expense of the buyer. Provided that the Warranty shall not be effective unless the seller receives a written claim within 30 days after the discovery of the defect. The seller shall have no obligation whatsoever to accept goods unless the provisions set forth in sub paragraph (1) have been complied with in full. Any goods that are returned to the seller shall be returned expressly, to the factory door of the seller, at the expense of the buyer. Any goods that are returned or replaced by the seller shall be warranted for the remaining term of this Warranty. The aforesaid remedy is expressly agreed to be the sole and exclusive remedy for breach of the Warranty, accordingly without limitation to the generality of the foregoing. The seller shall not be obligated in any way in the event of breach of the said Warranty to return any part of the purchase price of the goods or to give credit for any payments received.
  3. The foregoing Warranty is in lieu of all other warranties (except of title) express, implied (including without limitation the warranties of merchantability and fitness for any particular purpose) or statutory and all other liabilities (contract, tort or otherwise, including without limitation negligence), seller makes no warranty whatsoever express, implied, or statutory to any person or entity other than buyer. In no event whatsoever shall the seller be liable for loss of profits or any other incidental, consequential, or special damage resulting from any defects in the goods or any breach of the Warranty.



**PLEASE DISPLAY THIS NOTICE AT THE CHARGING POINT  
CORRECT CHARGING IS THE KEY POINT FOR  
GOOD POWER PACK HEALTH AND LIFE**

**RECHARGING**

1. Open the flap to expose the pack connections.
2. Plug the charger into the lower smaller connector. - Plug only fits one way round.
3. Connect the charger to a SUITABLE AC inlet 50 or 60Hz and switch **ON**.
4. Switch **ON** the charger.
5. Leave the pack on the charger until the **GREEN** light shows - This is approx. 90% charged.
6. If possible leave the pack connected to the charger to fully (100%) charge this may take several hours

**The Charger may be left connected for extended periods of time  
No damage will occur - This is good for the health of the pack**

**DO NOT leave charger connected to the pack and CHARGER SWITCHED OFF –**

7. To disconnect - Switch **OFF** the charger and AC supply.
8. Unplug the charger from the AC and the lead to the pack.

**WHEN IN REGULAR USE PUT IT ON CHARGE AND SOAK FOR 24 HRS EVERY 2 WEEKS**

- Only use the Voltage controlled charger supplied by Red Box
- If possible DO NOT wait until the pack is completely flat before recharging
- Put the pack back on charge as soon as possible after you have used it. And keep charged up as high as possible
- The pack does not have a memory and does not require cycling Charge anytime
- Fully charge for 24 hours before long storage
- The pack may be switched on when charging
- 

**CHARGE STATUS**

The charge status of the pack can be obtained by reading the digital voltmeter. The voltage shown is proportional to the level of charge in the pack. It is **not** an indication of the capacity of the pack.

- Disconnect all leads from the pack, including the charger.
- Switch on the pack and read the voltage.

**24 Volts = Flat**

(Discharged)  
**24 Volts = Flat**  
(Discharged)

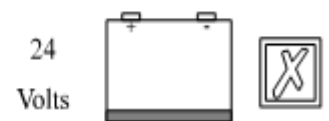

**26Volts = Fully Charged**

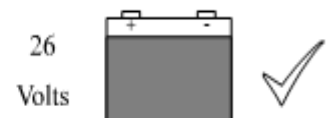

**NOTE**

- When removed from the charger the power pack may show a voltage in excess of 30 volts for a time. This is surface voltage, which will gradually decay or should disappear when the unit is connected to an aircraft.
- The power pack should be kept on the charger at least until the GREEN float light shows

**Operational Capacity of the unit MUST always be determined by the operator before use**



**RED BOX**  
AVIATION

**LPA Connection Systems**

Light & Power House

Shire Hill

Saffron Walden

Essex, UK

CB11 3AQ

+44 (0)1799 512800

[enquiries@lpa-connect.com](mailto:enquiries@lpa-connect.com)

[www.redboxaviation.com](http://www.redboxaviation.com)

[www.lpa-group.com](http://www.lpa-group.com)

