

FANS

AEROSPACE & MILITARY FANS CATALOG



2019 EDITION

- LMB
 - About Us p.3
 - From Design to Product p.3
 - Our Certifications p.3
 - Flexible Customer Support p.3
- Standard LMB Fan SPECIFICATION p.4
- DC Brushless Fans
 - Lenz p.6
 - Thinfan 50 p.6
 - Thinfan 52 p.6
 - Thinfan 58 p.7
 - Thinfan 60 p.8
 - Thinfan 80 p.8
 - Thinfan 120 p.9
 - Peltier / Pepite / Pourpier / Pluton p.10
 - Optifan 40 p.12
 - Optifan 44 p.14
 - Optifan 45 p.16
 - Optifan 65 p.18
 - Optifan 70 p.20
 - Optifan 75 p.22
 - Optifan 145 p.24
 - Optifan 80 p.26
- AC 400Hz Fans
 - Cumin p.28
 - Candi p.28
 - Cheri p.29
 - Mortier-1 p.29
 - Maxime 2 / Maxime 4 p.30
 - Maximal 2 / Maximal 4 p.31
 - Maryland-1 p.32
 - Media 2p5 p.32
 - Mercator p.33
 - Melba p.33
 - Prodige / Pasteur / Persan / Pensee / Pastel p.34
 - Optifan 145 p.36
 - Marathon 2 / Marathon 4 p.37
- Speed Signal p.38
- PWM p.39
- 0-5VDC p.40
- Accessories
 - C-Clamps p.42
 - Fingers guards p.43
- Equivalence of Units p.44
- Hyperfan curves p.47



www.lmbaerospace.com

ABOUT US

LMB, founded over 100 years ago, have become one of the leading suppliers of fans, blowers, motors and specialized rotating machines.

LMB design and manufacture high performance fans and both AC (50 / 60 Hz, 400Hz and Wild Frequency) and DC (12 – 300 VDC) Brushless motors for the aerospace and defence markets with applications in aircraft, helicopters, pods and ground military vehicles.

LMB produce a wide range of fans and motors (more than 1000 off the shelf qualified products). Our engineering and manufacturing departments give us an unparalleled ability for new development. For specific requirements, we are very flexible in designing custom products in short time spans and meeting MIL / DO standards.

FLEXIBLE CUSTOMER SUPPORT

Feel free to contact us for all your requirements for standard or customized products. We will then be pleased to demonstrate all our capabilities of reactivity and flexibility to adapt our standard products to your specific needs.

FROM DESIGN TO PRODUCTION

LMB offer all the capabilities to design, develop and produce on site your FANS, BLOWERS and MOTORS.

- Design
- Prototype development
- Performance and endurance tests
- Winding workshop
- Electronic workshop
- Machining line
- Assembly line

OUR CERTIFICATIONS

- ISO 9001 v2000
- EN/AS 9100
- PART 21G
- PART 145

FEEL FREE TO CONTACT US ABOUT OUR OTHER PRODUCTS (HIGH PERFORMANCE FANS, CENTRIFUGAL BLOWERS AND ELECTRICAL MOTORS).
 email : sales@lmbaerospace.com

- AIR CONDITIONING SYSTEMS
- AVIONICS COOLING
- UAVs / PODs / MISSILES
- RACK & BAY VENTILATION
- SCAVENGE
- COUNTER MEASURE SYSTEMS
- CABIN TEMPERATURE SENSOR
- RADAR



LMB FANS ARE DESIGNED TO FULFILL THE FOLLOWING ENVIRONMENTAL CONDITIONS :

CLIMATIC CONDITIONS

•Operating temperature range	-55 / +85°C
•Storage temperature range	-55 / +105°C (MIL-STD-810E, method 501.3 & 502.3)
•Altitude	MIL-STD-810E Method 500.3, Procedure 1 and 2 Normal operation for altitude variations up to 5000 ft/min up to an altitude of 50000 ft.
•Humidity	MIL-STD-810E Method 507.3, Procedure 1 Normal operation when relative humidity is higher or equal to 95% throughout the temperature range.
•Sand and dust	MIL-STD-810E Method 510.3 Normal operation with 50% reduced sand and dust concentration. Increased tip clearance (sand and dust) for 100 % concentration available as option.
•Sea spray	MIL-STD-810E Method 509.3, Procedure 1 (NaCl : 5%) Operating : 96 hrs / Non operating : 120 hrs
•Fungus	MIL-STD-810E Method 508.4 (28 days)

MECHANICAL CONDITIONS

• Vibration	MIL-STD-810F Method 514.5
• Shock	MIL-STD-810F Method 516.5, Procedure 1
• Acceleration	MIL-STD-810F Method 513.5, Procedure 2

LMB CUSTOMIZATION

LMB IS FLEXIBLE IN DESIGNING CUSTOM PRODUCTS :

MECHANICAL

- Servo ring
- Square flange
- 3 mounting points
- Round flange
- Flatted flange

ELECTRICAL

- Flying leads
- Shielded leads
- Terminal block
- MS Connector
- D38999 Connector

NOMINAL VOLTAGE

- From 12VDC to 48VDC

INPUT SIGNAL

- 0-5VDC speed control
- PWM speed control
- Two-speed

SPEED SIGNAL

- Low Speed Warning (LSW)
- Fan Performance Signal (FPS)
 - Open Collector
 - 5VDC, 7.5VDC, 10VDC or 12VDC
 - 30/rpm or 60/rpm

HARSH ENVIRONMENTAL CONDITIONS

- IP68 (potting)
- Painting finish
- Increased tip clearance for sand and dust

DC Brushless Fans

Part Number	Power Supply	Speed (rpm)	Input Power (Watts)	Input Current (Amps)	Starting Current (Amps)	Weight (Kg/Lbs)	Noise (dB(A))	Drawing	Curve	Speed Signal F.P.S	L.S.W
00000664	12 VDC	18000	27	2,2	-	0.32/0.71	87	Fig.1	Fig.A	-	-
00000958	28 VDC	18000	27	0,85	-	0.32/0.71	87	Fig.1	Fig.B	-	-

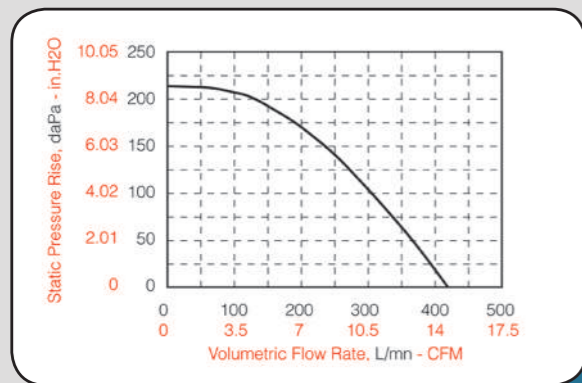

Fig.A

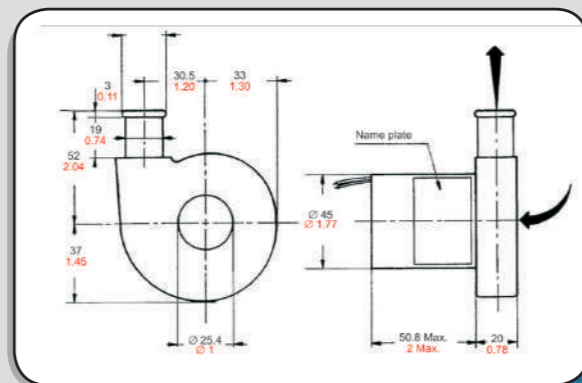

Fig.1

THINFAN 50

Part Number	Power Supply	Speed (rpm)	Input Power (Watts)	Input Current (Amps)	Starting Current (Amps)	Weight (Kg/Lbs)	Noise (dB(A))	Drawing	Curve	Speed Signal F.P.S	L.S.W	Speed Control** PWM
00-85001589-001	28 VDC	3000	0,6	0,022	0,15	0.035 / 0.077	32	Fig.1	Fig.A	✓	-	-
00-85001590-001	28 VDC	7500	2,7	0,097	0,15	0.035 / 0.077	38	Fig.2	Fig.B	✓	-	-

*Refer to page 38 speed signal, FPS: type5

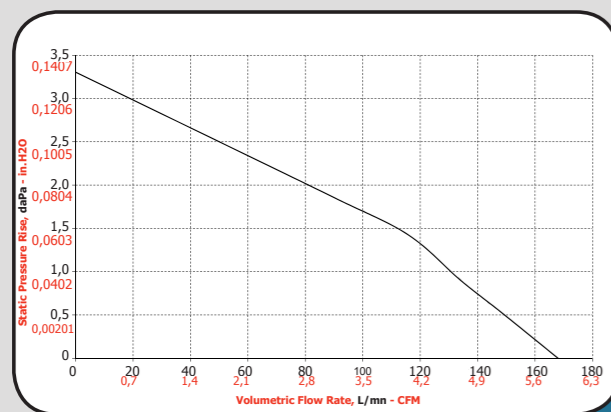

Fig.A

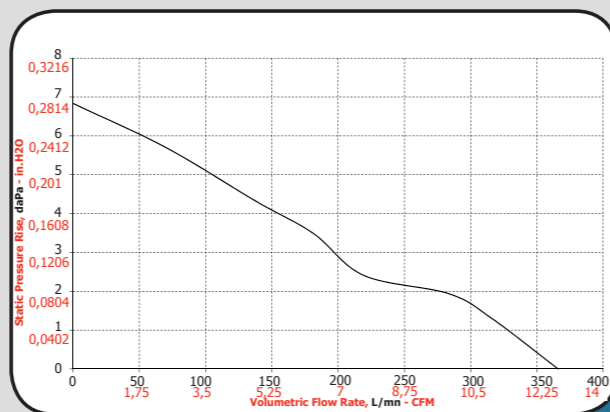

Fig.B

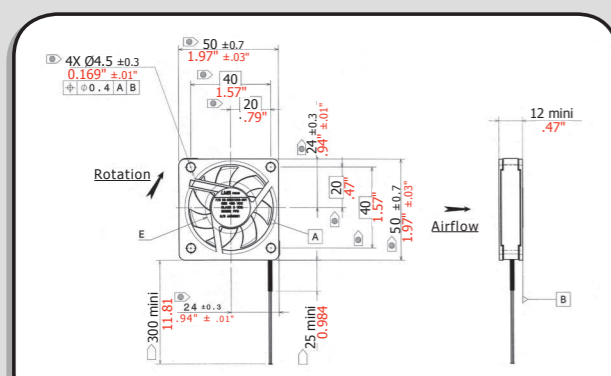

Fig.1

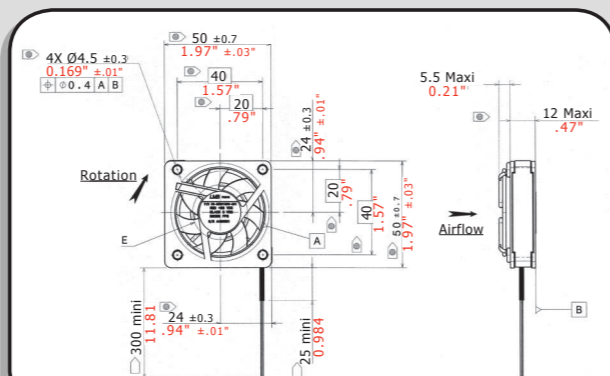

Fig.2

THINFAN 52

Part Number	Power Supply	Speed (rpm)	Input Power (Watts)	Input Current (Amps)	Starting Current (Amps)	Weight (Kg/Lbs)	Noise (dB(A))	Drawing	Curve	Speed Signal F.P.S	L.S.W	Speed Control** PWM
00-85001386-001	28 VDC	3000	0,6	0,022	0,15	0.035 / 0.077	32	Fig.1	Fig.A	✓	-	-
00-85001387-001	28 VDC	6500	1,8	0,063	0,15	0.035 / 0.077	38	Fig.2	Fig.B	✓	-	-
00-85001389-001	12 VDC	6500	1,4	0,12	0,2	0.035 / 0.077	38	Fig.2	Fig.B	✓	-	-
00-85001402-001	12 VDC	6500	1,4	0,12	0,2	0.035 / 0.077	38	Fig.1	Fig.B	✓	-	-
00-85001403-001	28 VDC	6500	1,8	0,063	0,15	0.035 / 0.077	38	Fig.1	Fig.B	✓	-	-
00-85001440-001	28 VDC	7500	2,7	0,097	0,15	0.035 / 0.077	38	Fig.2	Fig.C	✓	-	-
00-85001525-001	28 VDC	7500	2,7	0,097	0,15	0.035 / 0.077	38	Fig.1	Fig.C	✓	-	-
00-85001574-001	28 VDC	7500	2,7	0,097	0,15	0.035 / 0.077	38	Fig.1	Fig.C	✓	-	✓

*Refer to page 38 speed signal, FPS: type5 / Refer to page 42 «accessories» /** Refer to page 39 "PWM"

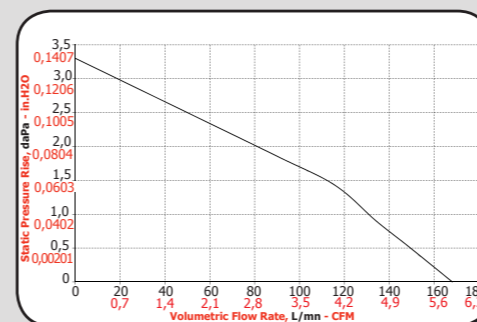

Fig.A

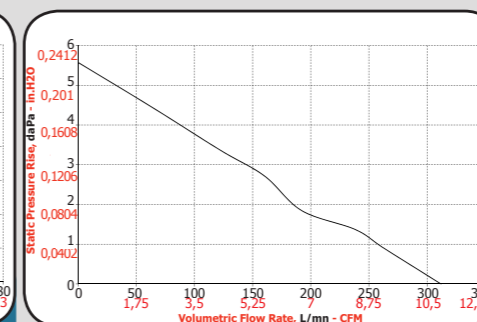

Fig.B

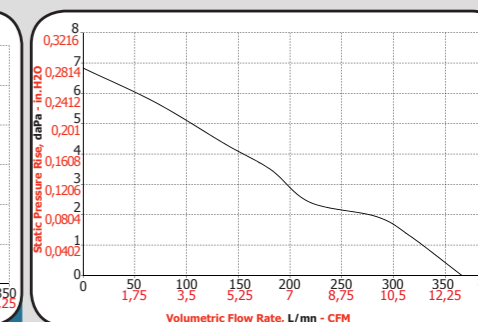

Fig.C

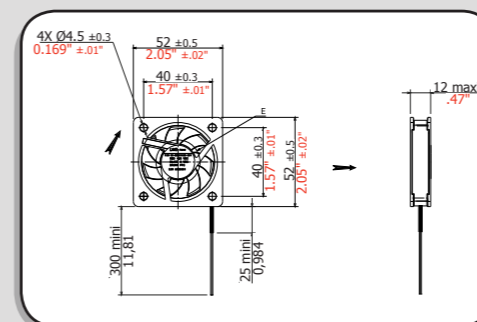

Fig.1

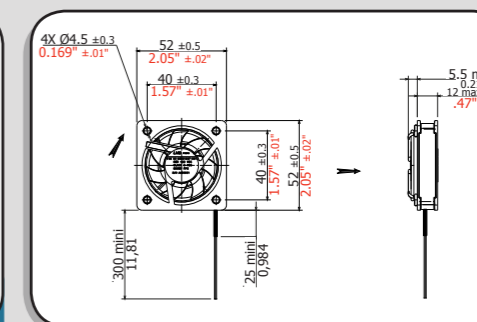

Fig.2

THINFAN 58

Part Number	Power Supply	Speed (rpm)	Input Power (Watts)	Input Current (Amps)	Starting Current (Amps)	Weight (Kg/Lbs)	Noise (dB(A))	Drawing	Curve	Speed Signal F.P.S	L.S.W	Speed Control** PWM
00-85001642-001	12 VDC	5500	3	0,25	0,35	0.055 / 0.121	38	Fig.1	Fig.A	✓	-	-
00-85001701-001	28 VDC	5500	3	0,1	0,25	0.055 / 0.121	38	Fig.1	Fig.A	✓	-	-
00-85001845-001	12 VDC	5500	3	0,25	0,35	0.055 / 0.121	38	Fig.1	Fig.A	✓	-	✓

*Refer to page 38 speed signal, FPS: type3 /** Refer to page 39 "PWM"

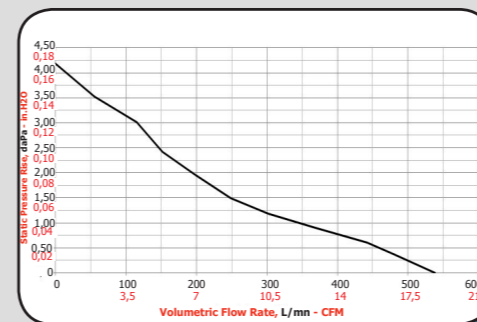

Fig.A

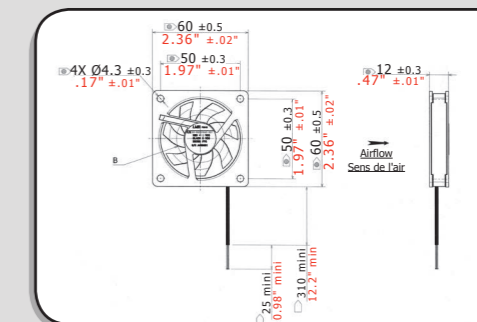

Fig.1

THINFAN 60

Part Number	Power Supply	Speed (rpm)	Input Power (Watts)	Input Current (Amps)	Starting Current (Amps)	Weight (Kg/Lbs)	Noise (dB(A))	Drawing	Curve	Speed Signal*		Speed Control** PWM
										F.P.S	L.S.W	
00-85001620-001	12 VDC	12000	12	1	2,3	0.115 / 0.253	60	Fig.1	Fig.A	✓	-	-
00-85001621-001	12 VDC	12000	12	1	2,3	0.115 / 0.253	60	Fig.1	Fig.A	-	✓	-
00-85001622-001	28 VDC	12000	12	0,43	2,3	0.115 / 0.253	60	Fig.1	Fig.A	✓	-	-
00-85001623-001	28 VDC	12000	12	0,43	2,3	0.115 / 0.253	60	Fig.1	Fig.A	-	✓	-
00-85001624-001	28 VDC	12000	12	0,43	2,3	0.115 / 0.253	60	Fig.1	Fig.A	✓	-	✓

*Refer to page 38 speed signal, FPS: type 2 / **Refer to page 39 «PWM» / Refer to page 42 «Accessories»

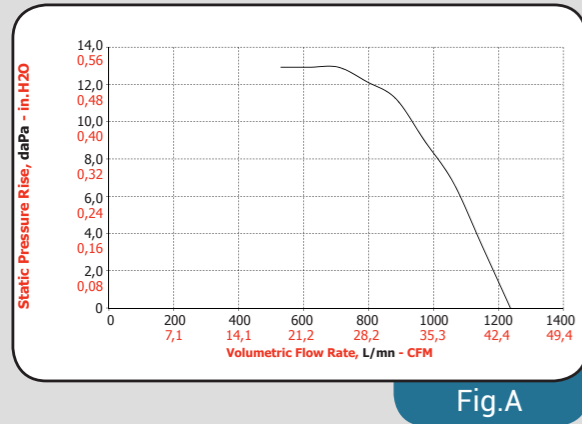

Fig.A

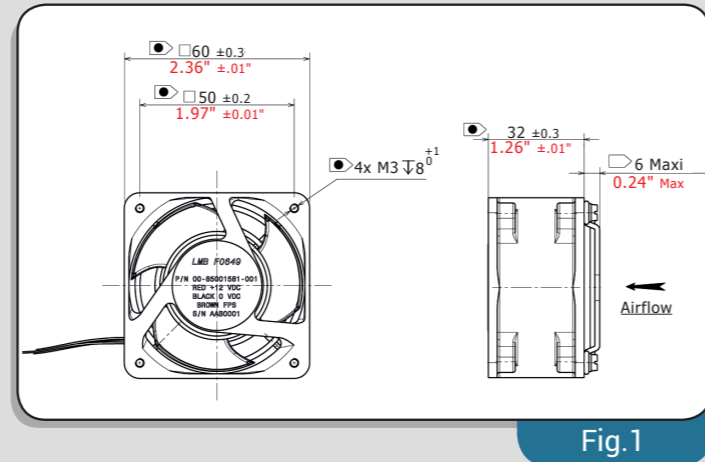

Fig.1

THINFAN 120

Part Number	Power Supply	Speed (rpm)	Input Power (Watts)	Input Current (Amps)	Starting Current (Amps)	Weight (Kg/Lbs)	Noise (dB(A))	Drawing	Curve	Speed Signal*		Speed Control** PWM	
										F.P.S	L.S.W	0-5 VDC	PWM
00-85001630-001	24 VDC	8000	34	1,4	5,0	0,45 / 1,0	35	Fig.1	Fig.A	✓	-	-	-
00-85001563-002	28 VDC	11000	78	2,8	5,0	0,45 / 1,0	65	Fig.1	Fig.B	✓	-	-	-
00-85001613-001	28 VDC	11000	78	2,8	5,0	0,45 / 1,0	65	Fig.1	Fig.B	✓	-	✓	-
00-85001714-001	28 VDC	11000	78	2,8	5,0	0,45 / 1,0	65	Fig.1	Fig.B	✓	-	-	✓
00-85001762-001	28 VDC	15000	196	7	10	0,6 / 1,32	68	Fig.2	Fig.C	✓	-	-	-

*Refer to page 38 speed signal, FPS: type 2 / ** Refer to page 39 "PWM" / *** Refer to page 41 "0-5 VDC"

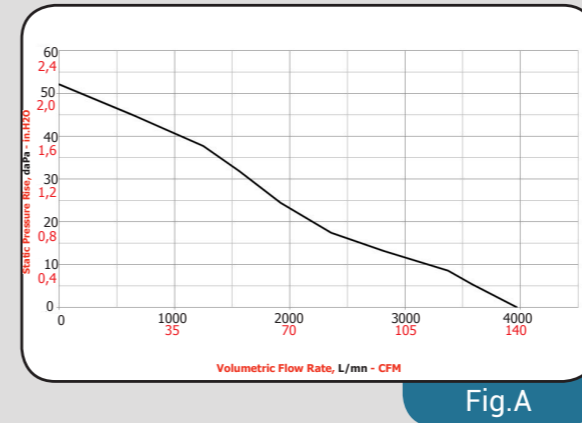

Fig.A

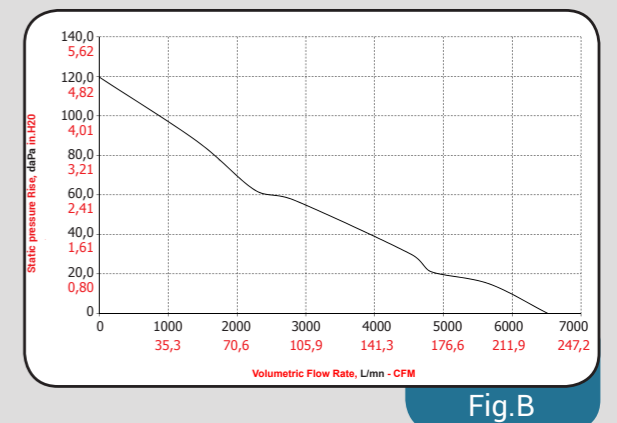

Fig.B

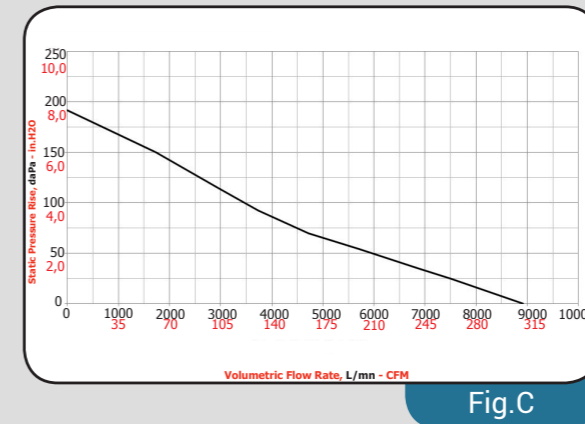

Fig.C

THINFAN 80

Part Number	Power Supply	Speed (rpm)	Input Power (Watts)	Input Current (Amps)	Starting Current (Amps)	Weight (Kg/Lbs)	Noise (dB(A))	Drawing	Curve	Speed Signal*		Speed Control** PWM
										F.P.S	L.S.W	
00-85001790-001	24 VDC	10500	32,4	1,35	2,4	0.35 / 0.62	70	Fig.1	Fig.A	✓	-	-
00-85001746-001	28 VDC	14000	56	2,0	3,0	0.35 / 0.62	76	Fig.1	Fig.B	✓	-	-

*Refer to page 38 speed signal, FPS: type 1

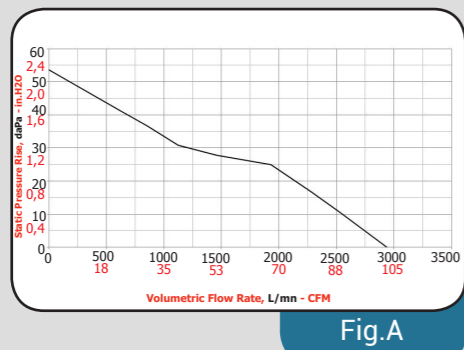

Fig.A

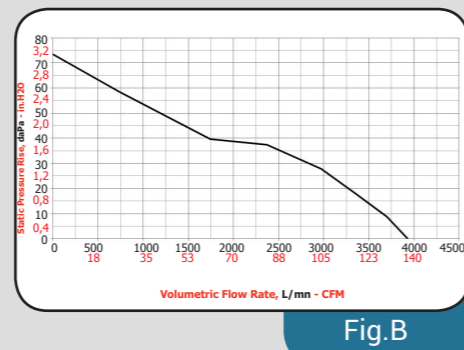

Fig.B

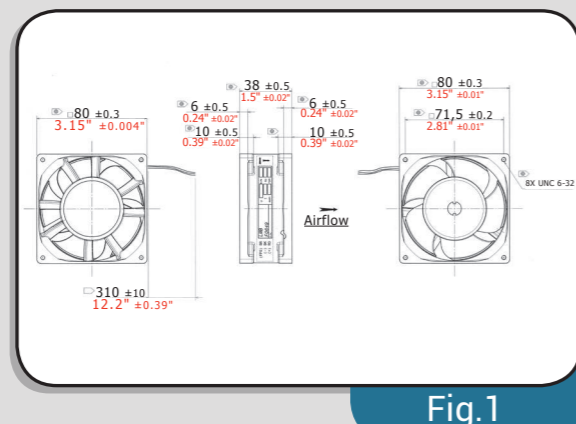

Fig.1

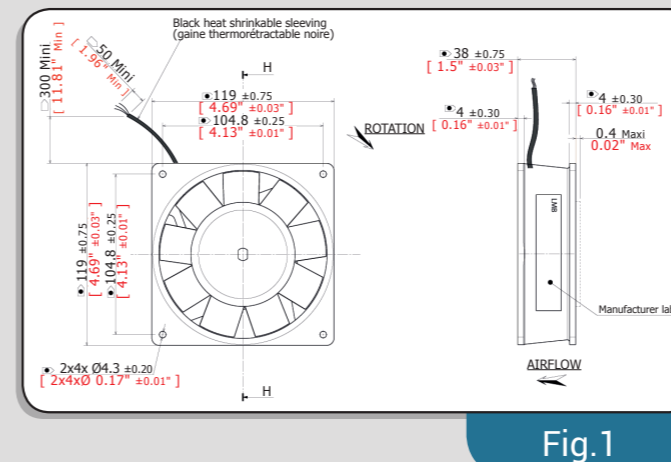

Fig.1

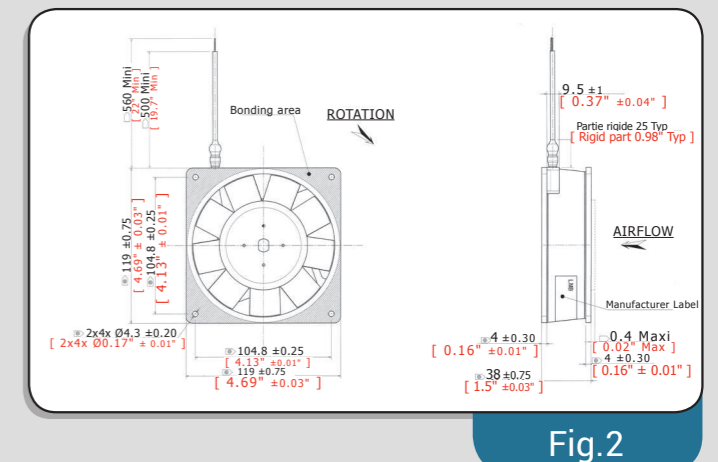

Fig.2

	Part Number	Power Supply	Speed (rpm)	Input Power (Watts)	Input Current (Amps)	Starting Current (Amps)	Weight (Kg/Lbs)	Noise (dB(A))	Drawing	Curve	Speed Signal+/**	
											F.P.S	L.S.W
PELTIER	00000737	26 VDC	5500	7	0.26	1.6	0.210/0.463	55	Fig.1	Fig.A	✓	-
PEPITE	00000914	26 VDC	3700	4	0.15	1	0.310/0.685	60	Fig.2	Fig.G	-	-
	00000936	26 VDC	4035	5	0.19	1.2	0.310/0.685	62	Fig.2	Fig.H	-	-
POURPIER	00000507	26 VDC	6400	13	0.5	3	0.310/0.685	72	Fig.2	Fig.B	-	-
	00000628	12 VDC	5000	9	0.8	2.25	0.23 / 0.51	66	Fig.3	Fig.C	-	-
PLUTON	00000790	26 VDC	5600	12	0.46	2	0.23 / 0.51	66	Fig.3	Fig.C	✓	-
	00001255	26 VDC	7300	22	0.8	3.5	0.23 / 0.51	73	Fig.3	Fig.F	✓	-
PLUTON	00000625	26 VDC	3500	8	0.3	1.34	0.45 / 1	63	Fig.4	Fig.D	✓**	-
	00000771	24 VDC	3800	9	0.4	1.9	0.45 / 1	63	Fig.4	Fig.E	✓**	-
	00001274	28 VDC	6000	42	1.5	3	0.45 / 1	68	Fig.4	Fig.I	✓*	-

* Refer to page 38 «speed signal», FPS: type 3

** Refer to page 38 «speed signal», FPS: type 1 / Refer to page 42 «accessories»

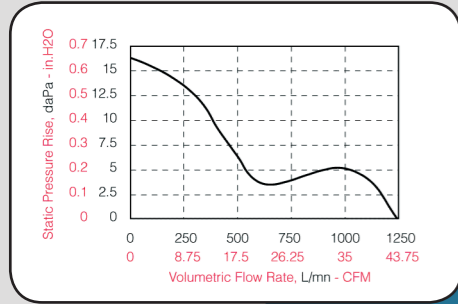

Fig.A

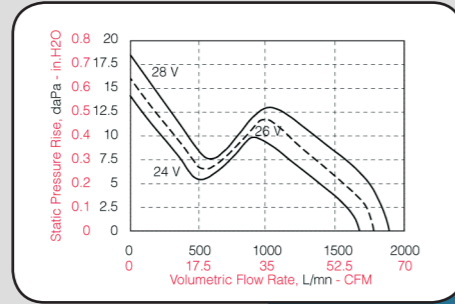

Fig.B

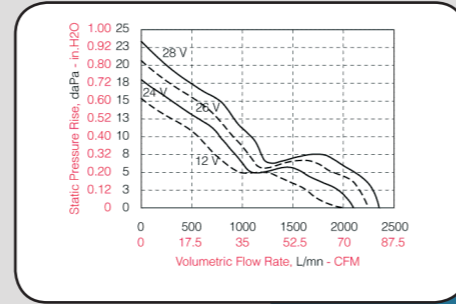

Fig.C

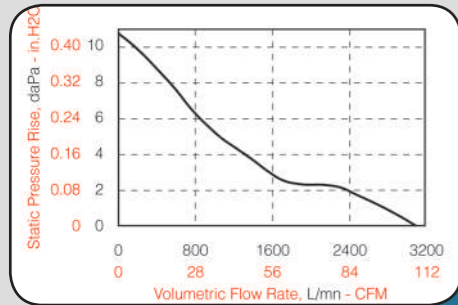

Fig.D

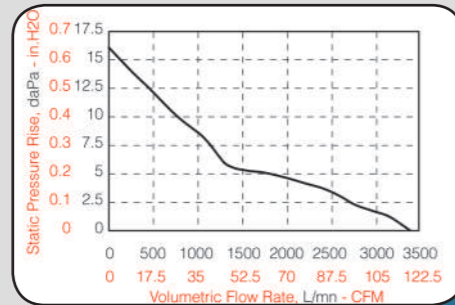

Fig.E

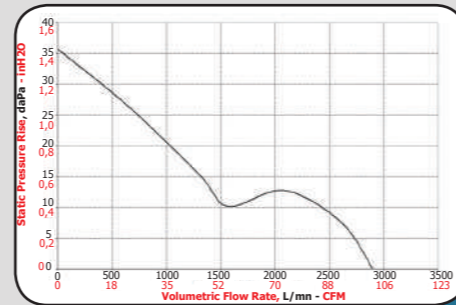

Fig.F

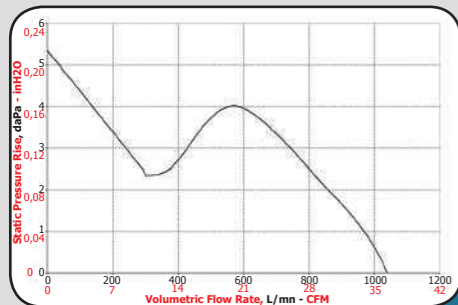

Fig.G

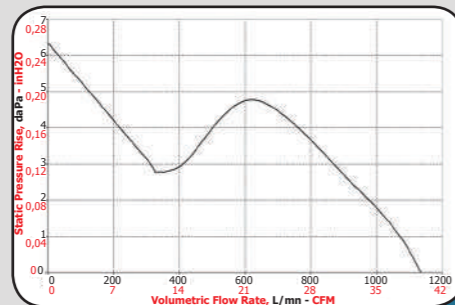

Fig.H

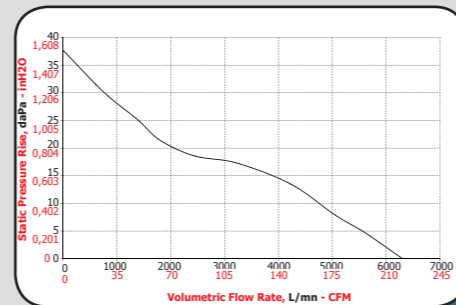

Fig.I

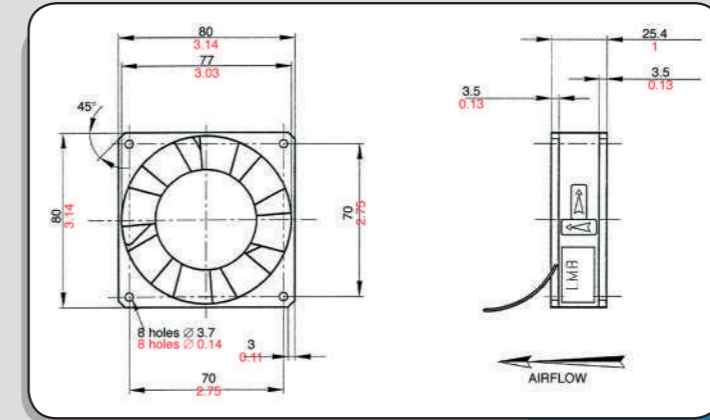

Fig.1

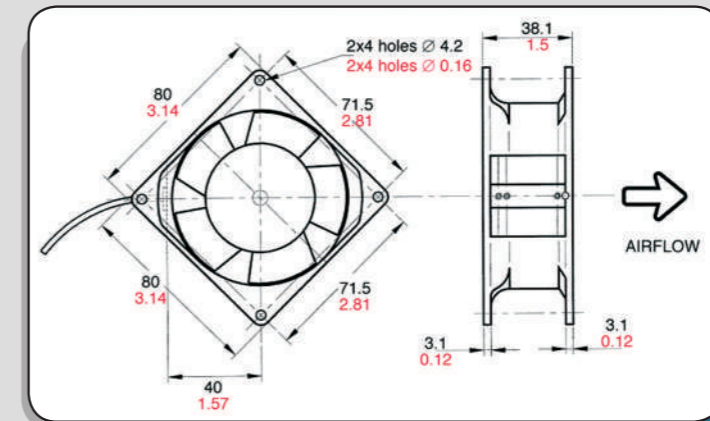

Fig.2

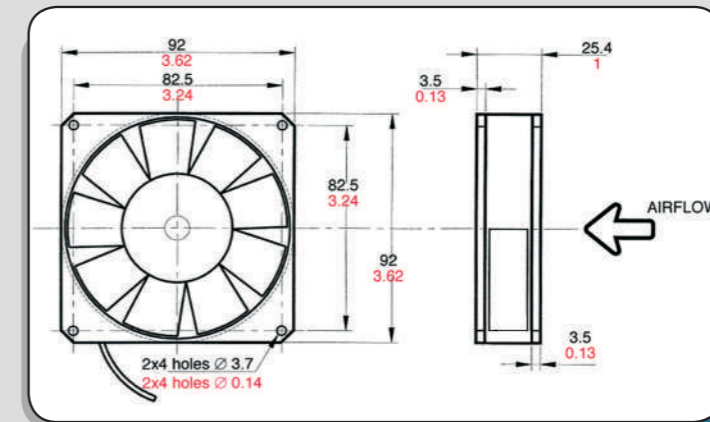

Fig.3

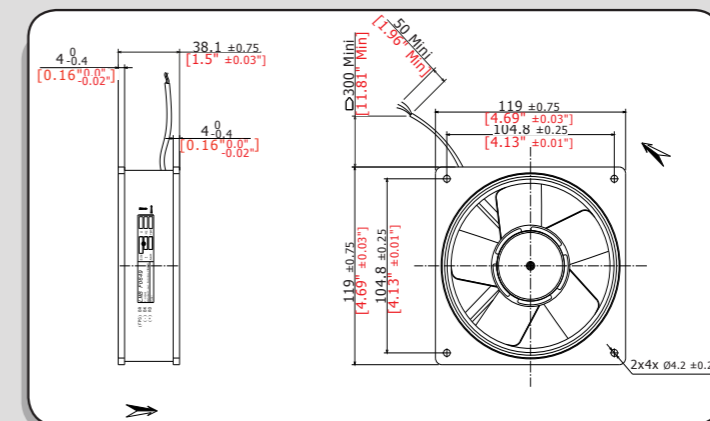

Fig.4

Part Number	Power Supply	Speed (rpm)	Input Power (Watts)	Input Current (Amps)	Starting Current (Amps)	Weight (Kg/Lbs)	Noise (dB(A))	Drawing	Curve	Speed Signal*		Speed Control** PWM
										F.P.S	L.S.W	
00001086	26 VDC	17000	9	0,35	2,2	0,08 / 0,18	62	Fig.1	Fig.A	✓	-	-
00001153	26 VDC	17000	9	0,35	2,2	0,08 / 0,18	62	Fig.1	Fig.A	-	✓	-
00001121	26 VDC	17000	9	0,35	2,2	0,08 / 0,18	62	Fig.2	Fig.A	✓	-	-
00001154	26 VDC	17000	9	0,35	2,2	0,08 / 0,18	62	Fig.2	Fig.A	-	✓	-
00001155	26 VDC	17000	9	0,35	2,2	0,08 / 0,18	62	Fig.3	Fig.A	✓	-	-
00001156	26 VDC	17000	9	0,35	2,2	0,08 / 0,18	62	Fig.3	Fig.A	-	✓	-
00001157	26 VDC	26000	26	1	2,2	0,08 / 0,18	78	Fig.1	Fig.B	✓	-	-
00001158	26 VDC	26000	26	1	2,2	0,08 / 0,18	78	Fig.1	Fig.B	-	✓	-
00001159	26 VDC	26000	26	1	2,2	0,08 / 0,18	78	Fig.2	Fig.B	✓	-	-
00001160	26 VDC	26000	26	1	2,2	0,08 / 0,18	78	Fig.2	Fig.B	-	✓	-
00001161	26 VDC	26000	26	1	2,2	0,08 / 0,18	78	Fig.3	Fig.B	✓	-	-
00001162	26 VDC	26000	26	1	2,2	0,08 / 0,18	78	Fig.3	Fig.B	-	✓	-
00-85001445-001	26 VDC	26000	26	1	2,2	0,08 / 0,18	78	Fig.1	Fig.B	✓	-	✓

* Refer to page 38 «speed signal», FPS: type 2 / ** Refer to page 39 «PWM» / Refer to page 42 «accessories»

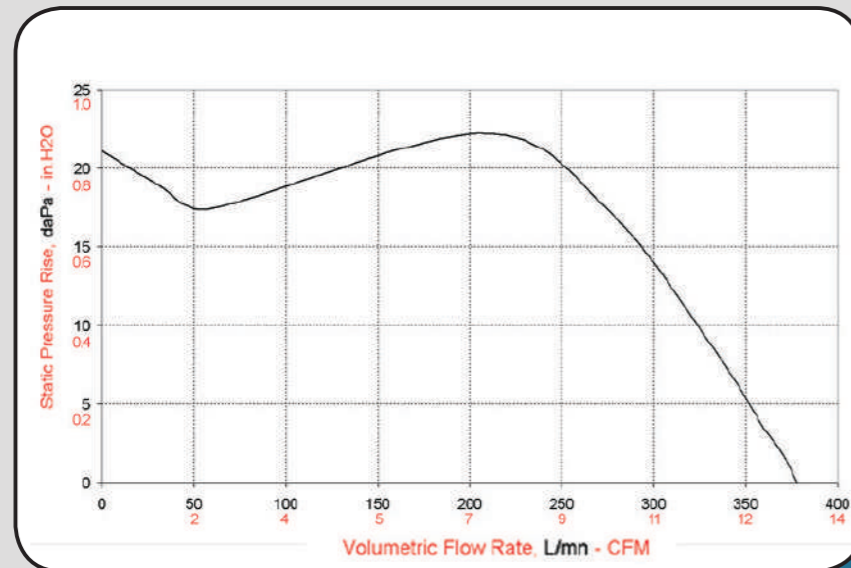

Fig.A

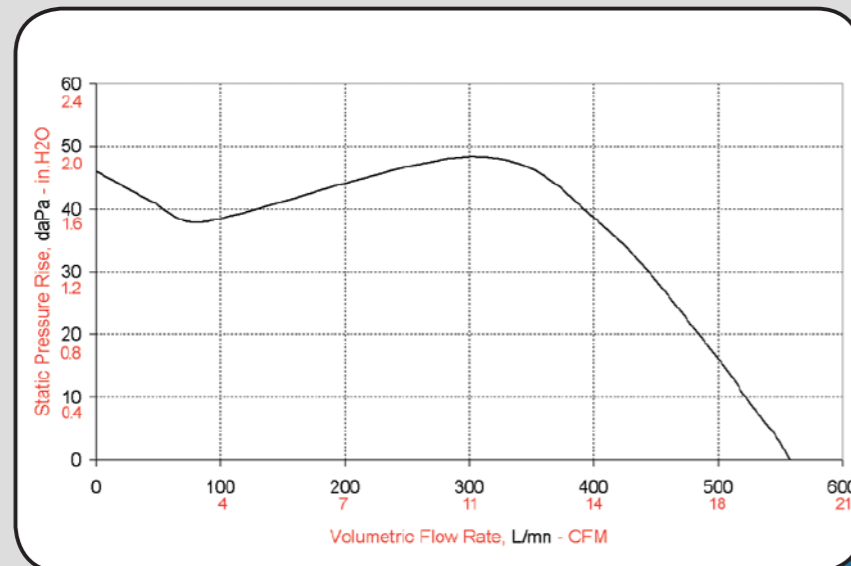

Fig.B

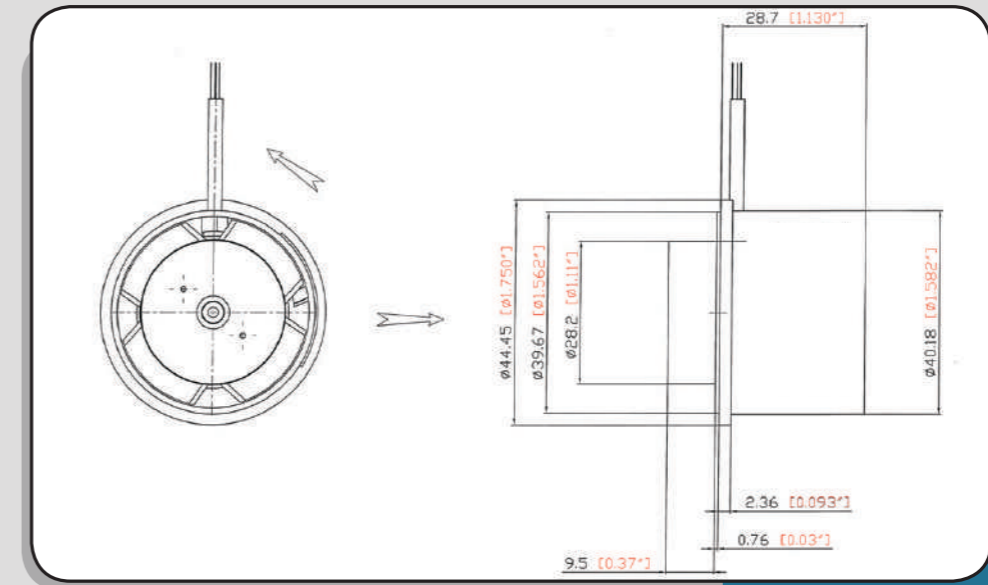

Fig.1

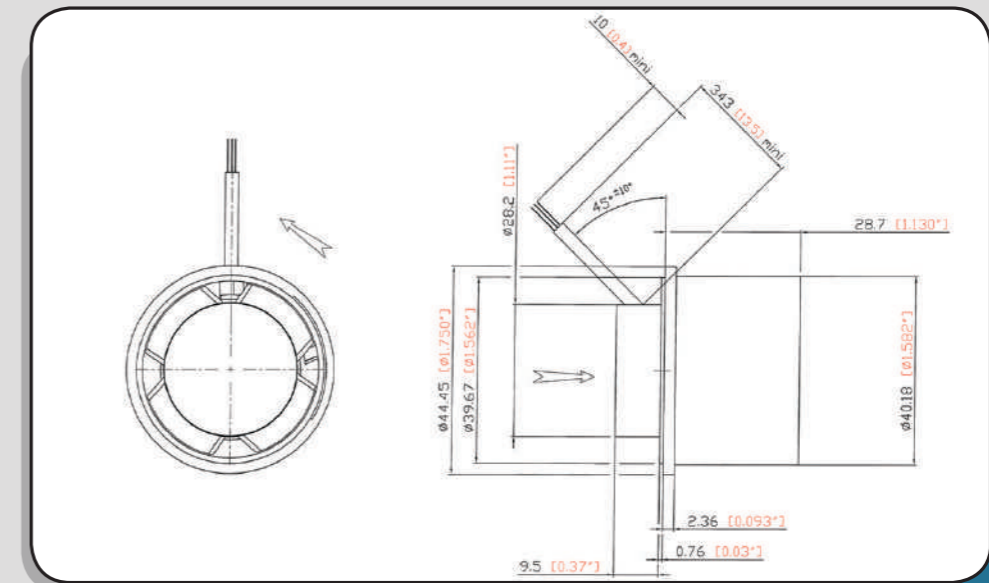

Fig.2

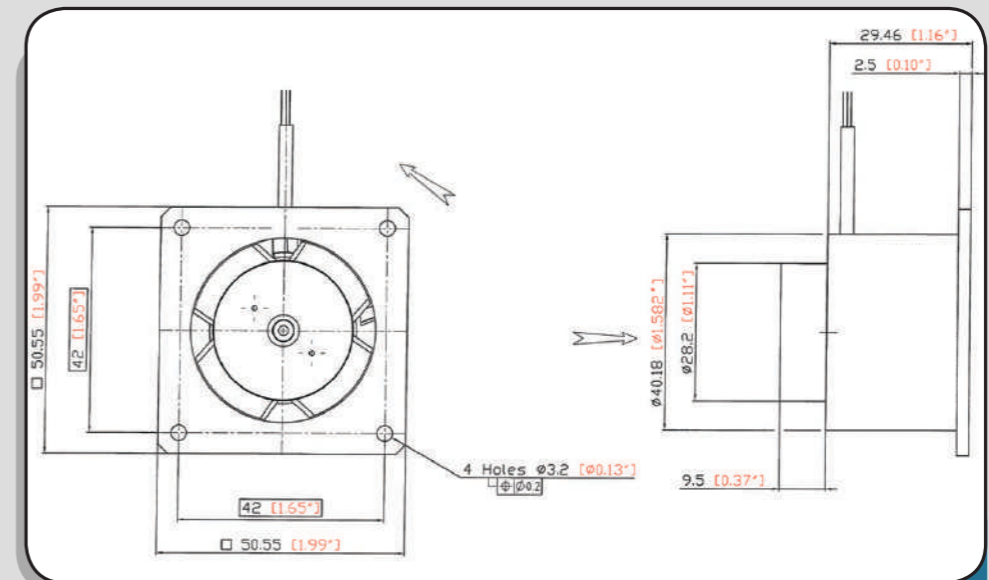

Fig.3

Part Number	Power Supply	Speed (rpm)	Input Power (Watts)	Input Current (Amps)	Starting Current (Amps)	Weight (Kg/Lbs)	Noise (dB(A))	Drawing	Curve	Speed Signal*		Speed Control** PWM
										F.P.S	L.S.W	
00001283	12 VDC	9500	3,2	0,25	0,8	0,09 / 0,2	58	Fig.1	Fig.A	✓	-	-
00001261	28 VDC	9500	3,2	0,12	0,8	0,09 / 0,2	58	Fig.1	Fig.A	✓	-	-
00001265	28 VDC	9500	3,2	0,12	0,8	0,09 / 0,2	58	Fig.2	Fig.A	✓	-	-
00001163	28 VDC	15000	6,5	0,23	2,2	0,09 / 0,2	68	Fig.1	Fig.B	✓	-	-
00001164	28 VDC	15000	6,5	0,23	2,2	0,09 / 0,2	68	Fig.1	Fig.B	-	✓	-
00001165	28 VDC	15000	6,5	0,23	2,2	0,09 / 0,2	68	Fig.2	Fig.B	✓	-	-
00001166	28 VDC	15000	6,5	0,23	2,2	0,09 / 0,2	68	Fig.2	Fig.B	-	✓	-
00001167	28 VDC	15000	6,5	0,23	2,2	0,09 / 0,2	68	Fig.3	Fig.B	✓	-	-
00001168	28 VDC	15000	6,5	0,23	2,2	0,09 / 0,2	68	Fig.3	Fig.B	-	✓	-
00-85001384-001	28 VDC	15000	6,5	0,23	2,2	0,09 / 0,2	68	Fig.4	Fig.B	-	✓	-
00001032	28 VDC	19000	12	0,43	2,2	0,09 / 0,2	74	Fig.1	Fig.C	✓	-	-
00001169	28 VDC	19000	12	0,43	2,2	0,09 / 0,2	74	Fig.1	Fig.C	-	✓	-
00001081	28 VDC	19000	12	0,43	2,2	0,09 / 0,2	74	Fig.2	Fig.C	✓	-	-
00001170	28 VDC	19000	12	0,43	2,2	0,09 / 0,2	74	Fig.2	Fig.C	-	✓	-
00001171	28 VDC	19000	12	0,43	2,2	0,09 / 0,2	74	Fig.3	Fig.C	✓	-	-
00001172	28 VDC	19000	12	0,43	2,2	0,09 / 0,2	74	Fig.3	Fig.C	-	✓	-
00001033	28 VDC	27000	24	0,85	2,2	0,09 / 0,2	84	Fig.1	Fig.D	✓	-	-
00001173	28 VDC	27000	24	0,85	2,2	0,09 / 0,2	84	Fig.1	Fig.D	-	✓	-
00001080	28 VDC	27000	24	0,85	2,2	0,09 / 0,2	84	Fig.2	Fig.D	✓	-	-
00001174	28 VDC	27000	24	0,85	2,2	0,09 / 0,2	84	Fig.2	Fig.D	-	✓	-
00001115	28 VDC	27000	24	0,85	2,2	0,09 / 0,2	84	Fig.3	Fig.D	✓	-	-
00001175	28 VDC	27000	24	0,85	2,2	0,09 / 0,2	84	Fig.3	Fig.D	-	✓	-
00-85001367-001	28 VDC	32000	37	1,29	2,2	0,09 / 0,2	85	Fig.1	Fig.E	✓	-	-
00-85001369-001	28 VDC	32000	37	1,29	2,2	0,09 / 0,2	85	Fig.1	Fig.E	-	✓	-
00-85001446-001	28 VDC	32000	37	1,29	2,2	0,09 / 0,2	85	Fig.1	Fig.E	✓	-	✓

* Refer to page 38 «speed signal», FPS: type 2 / ** Refer to page 39 «PWM» / Refer to page 42 «accessories»

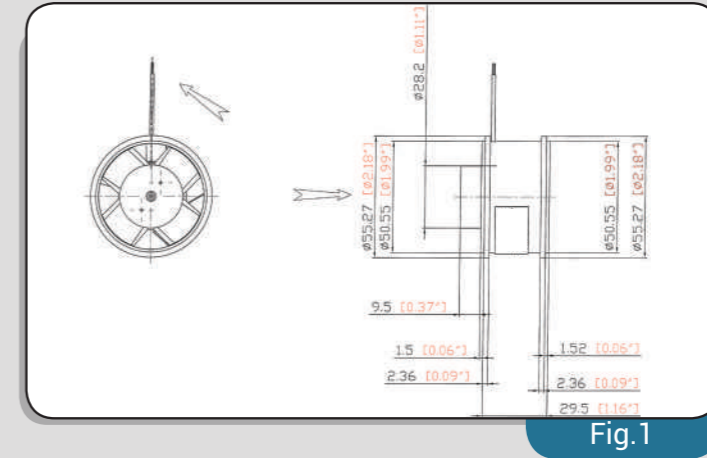

Fig.1

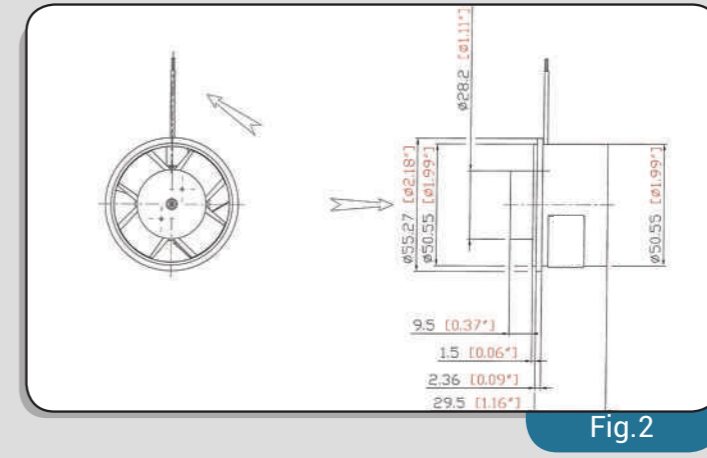

Fig.2

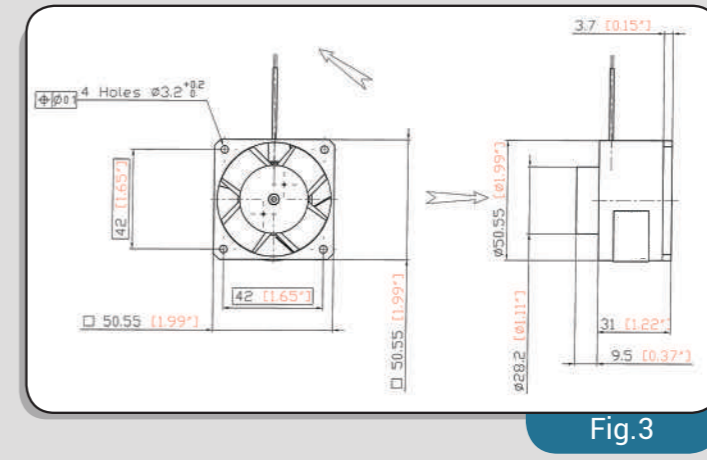

Fig.3

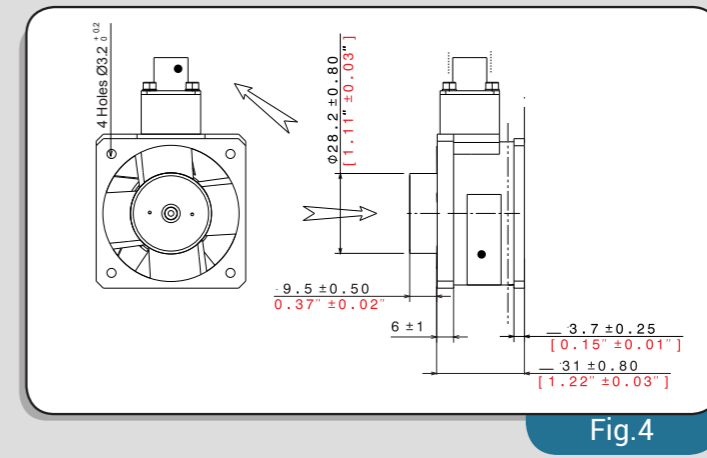

Fig.4

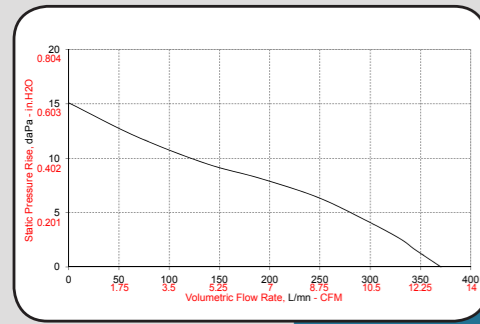

Fig.A

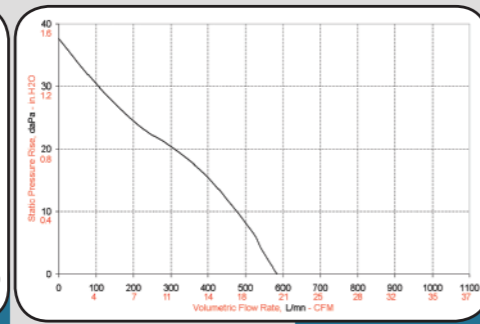

Fig.B

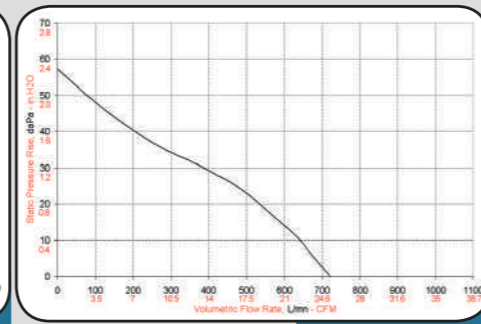

Fig.C

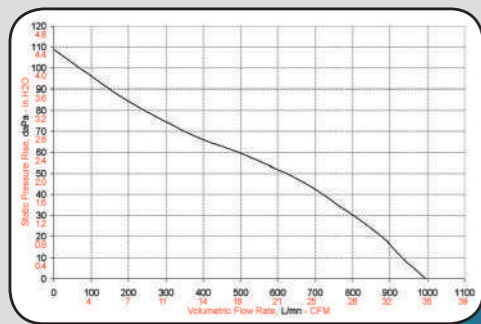

Fig.D

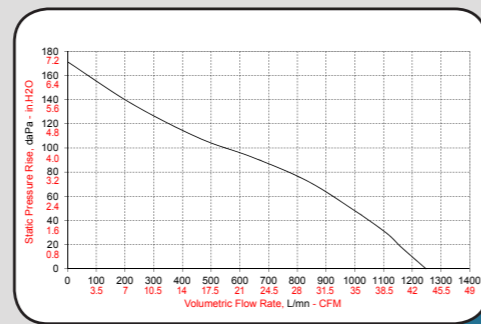

Fig.E

Part Number	Power Supply	Speed (rpm)	Input Power (Watts)	Input Current (Amps)	Starting Current (Amps)	Weight (Kg/Lbs)	Noise (dB(A))	Drawing	Curve	Speed Signal*		Speed Control** PWM
										F.P.S	L.S.W	
00-85001375-001	28 VDC	9500	6,5	0,23	2,2	0,12 / 0,27	60	Fig.1	Fig.A	✓	-	-
00-85001447-001	28 VDC	9500	6,5	0,23	2,2	0,12 / 0,27	60	Fig.1	Fig.A	-	✓	-
00-85001448-001	28 VDC	9500	6,5	0,23	2,2	0,12 / 0,27	60	Fig.2	Fig.A	✓	-	-
00-85001449-001	28 VDC	9500	6,5	0,23	2,2	0,12 / 0,27	60	Fig.2	Fig.A	-	✓	-
00-85001450-001	28 VDC	9500	6,5	0,23	2,2	0,12 / 0,27	60	Fig.3	Fig.A	✓	-	-
00-85001451-001	28 VDC	9500	6,5	0,23	2,2	0,12 / 0,27	60	Fig.3	Fig.A	-	✓	-
00-85001452-001	28 VDC	9500	6,5	0,23	2,2	0,12 / 0,27	60	Fig.4	Fig.A	✓	-	-
00-85001453-001	28 VDC	9500	6,5	0,23	2,2	0,12 / 0,27	60	Fig.4	Fig.A	-	✓	-
00-85001382-001	28 VDC	14500	18	0,6	2,2	0,12 / 0,27	71	Fig.5	Fig.B	✓	-	-
00001043	28 VDC	14500	18	0,6	2,2	0,12 / 0,27	71	Fig.1	Fig.B	✓	-	-
00001176	28 VDC	14500	18	0,6	2,2	0,12 / 0,27	71	Fig.1	Fig.B	-	✓	-
00001005	28 VDC	14500	18	0,6	2,2	0,12 / 0,27	71	Fig.2	Fig.B	✓	-	-
00001177	28 VDC	14500	18	0,6	2,2	0,12 / 0,27	71	Fig.2	Fig.B	-	✓	-
00001178	28 VDC	14500	18	0,6	2,2	0,12 / 0,27	71	Fig.3	Fig.B	✓	-	-
00001179	28 VDC	14500	18	0,6	2,2	0,12 / 0,27	71	Fig.3	Fig.B	-	✓	-
00001001	28 VDC	14500	18	0,6	2,2	0,12 / 0,27	71	Fig.4	Fig.B	✓	-	-
00001180	28 VDC	14500	18	0,6	2,2	0,12 / 0,27	71	Fig.4	Fig.B	-	✓	-
00001038	28 VDC	18000	25	0,9	2,2	0,12 / 0,27	78	Fig.1	Fig.C	✓	-	-
00001181	28 VDC	18000	25	0,9	2,2	0,12 / 0,27	78	Fig.1	Fig.C	-	✓	-
00001182	28 VDC	18000	25	0,9	2,2	0,12 / 0,27	78	Fig.2	Fig.C	✓	-	-
00001183	28 VDC	18000	25	0,9	2,2	0,12 / 0,27	78	Fig.2	Fig.C	-	✓	-
00001184	28 VDC	18000	25	0,9	2,2	0,12 / 0,27	78	Fig.3	Fig.C	✓	-	-
00001185	28 VDC	18000	25	0,9	2,2	0,12 / 0,27	78	Fig.3	Fig.C	-	✓	-
00000954	28 VDC	18000	25	0,9	2,2	0,12 / 0,27	78	Fig.4	Fig.C	✓	-	-
00001186	28 VDC	18000	25	0,9	2,2	0,12 / 0,27	78	Fig.4	Fig.C	-	✓	-
00001123	28 VDC	20000	34	1,2	2,2	0,12 / 0,27	80	Fig.1	Fig.D	✓	-	-
00001187	28 VDC	20000	34	1,2	2,2	0,12 / 0,27	80	Fig.1	Fig.D	-	✓	-
00001188	28 VDC	20000	34	1,2	2,2	0,12 / 0,27	80	Fig.2	Fig.D	✓	-	-
00001189	28 VDC	20000	34	1,2	2,2	0,12 / 0,27	80	Fig.2	Fig.D	-	✓	-
00001190	28 VDC	20000	34	1,2	2,2	0,12 / 0,27	80	Fig.3	Fig.D	✓	-	-
00001191	28 VDC	20000	34	1,2	2,2	0,12 / 0,27	80	Fig.3	Fig.D	-	✓	-
00000979	28 VDC	20000	34	1,2	2,2	0,12 / 0,27	80	Fig.4	Fig.D	✓	-	-
00001192	28 VDC	20000	34	1,2	2,2	0,12 / 0,27	80	Fig.4	Fig.D	-	✓	-
00001109	28 VDC	22000	42	1,5	2,2	0,12 / 0,27	85	Fig.1	Fig.E	✓	-	-
00001193	28 VDC	22000	42	1,5	2,2	0,12 / 0,27	85	Fig.1	Fig.E	-	✓	-
00001194	28 VDC	22000	42	1,5	2,2	0,12 / 0,27	85	Fig.2	Fig.E	✓	-	-
00001195	28 VDC	22000	42	1,5	2,2	0,12 / 0,27	85	Fig.2	Fig.E	-	✓	-
00001023	28 VDC	22000	42	1,5	2,2	0,12 / 0,27	85	Fig.3	Fig.E	✓	-	-
00001196	28 VDC	22000	42	1,5	2,2	0,12 / 0,27	85	Fig.3	Fig.E	-	✓	-
00001132	28 VDC	22000	42	1,5	2,2	0,12 / 0,27	85	Fig.4	Fig.E	✓	-	-
00001197	28 VDC	22000	42	1,5	2,2	0,12 / 0,27	85	Fig.4	Fig.E	-	✓	-
00-85001420-001	31 VDC	22000	42	1,5	2,2	0,12 / 0,27	85	Fig.6	Fig.E	✓	-	-
00-85001411-001	28 VDC	22000	42	1,5	2,2	0,12 / 0,27	85	Fig.1	Fig.E	✓	-	✓

* Refer to page 38 «speed signal», FPS: type 2 / ** Refer to page 39 «PWM» / Refer to page 42 «accessories»

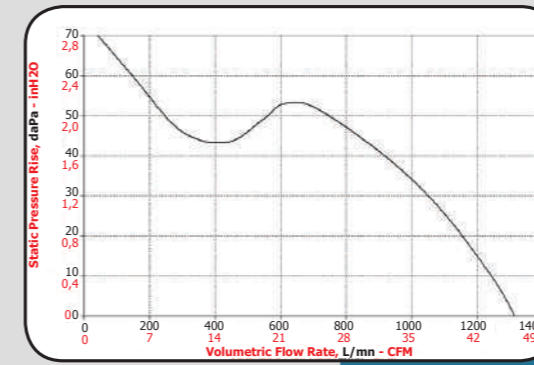

Fig.D

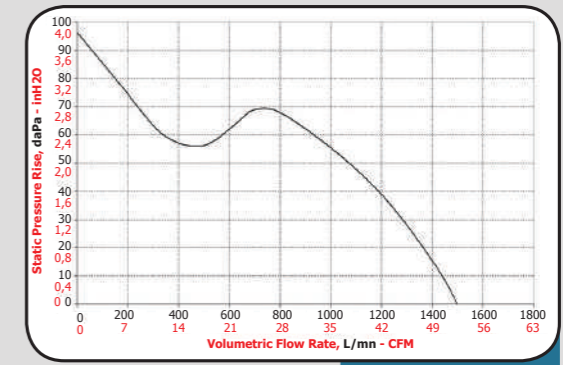

Fig.E

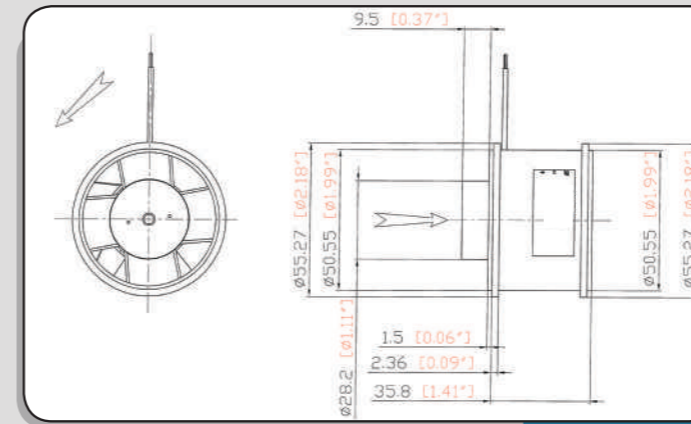

Fig.1

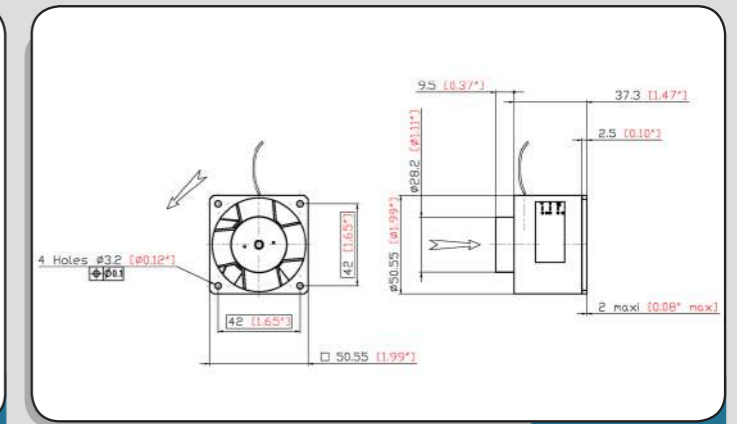

Fig.2

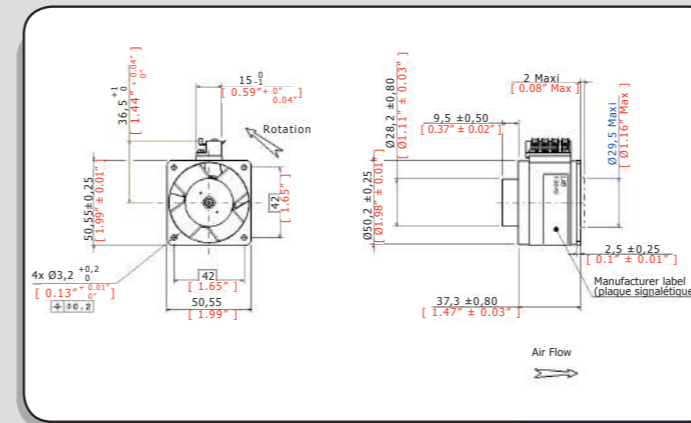

Fig.3

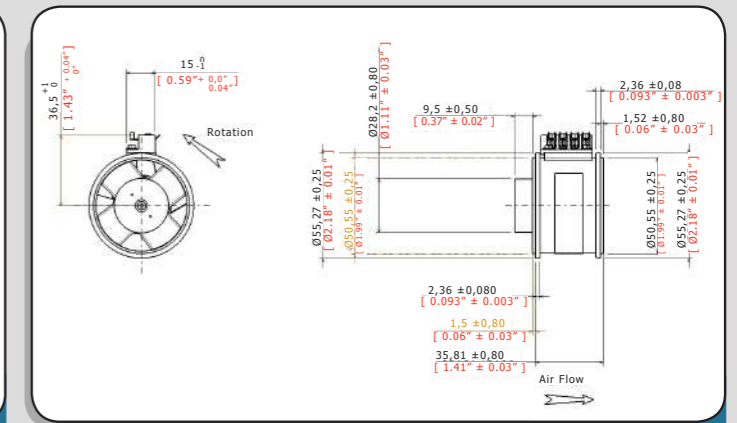

Fig.4

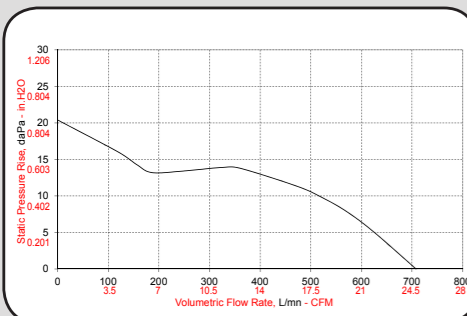

Fig.A

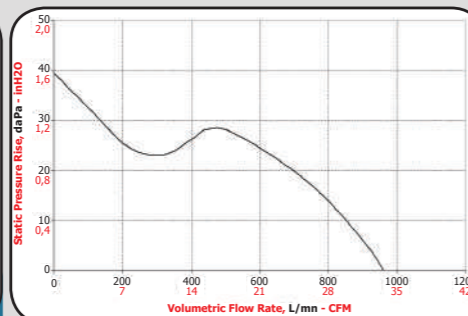

Fig.B

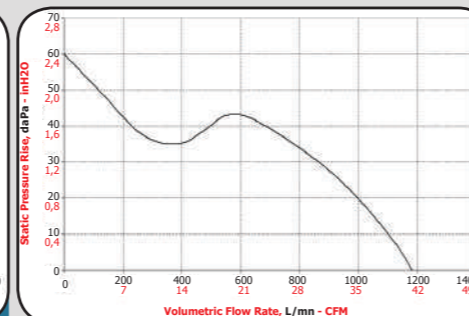

Fig.C

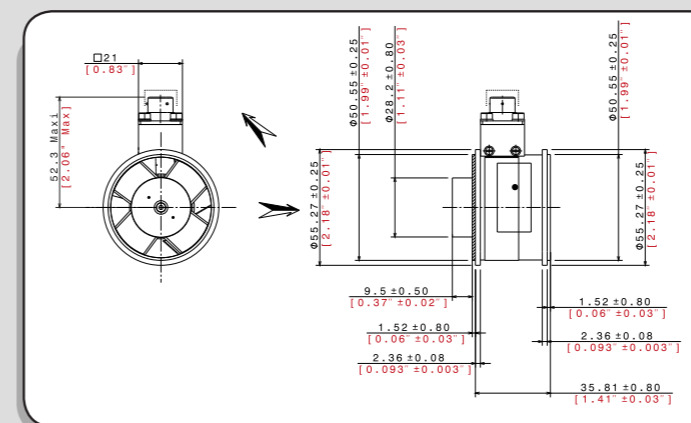

Fig.5

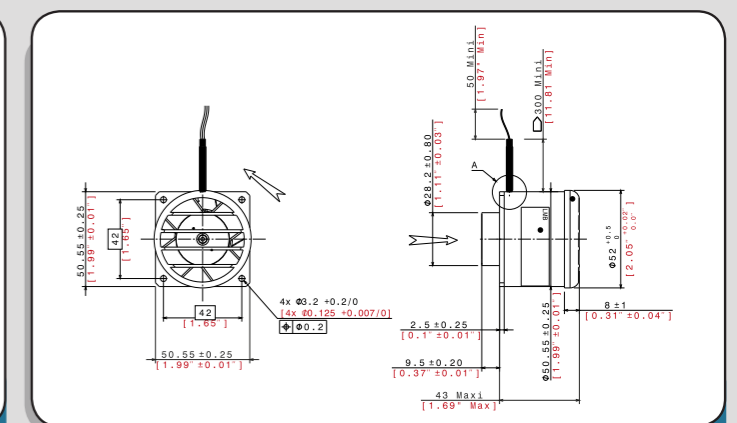

Fig.6

Part Number	Power Supply	Speed (rpm)	Input Power (Watts)	Input Current (Amps)	Starting Current (Amps)	Weight (Kg/Lbs)	Noise (dB(A))	Drawing	Curve	Speed Signal/**	
										F.P.S	L.S.W
00001198	28 VDC	9500	12	0,4	2,2	0,3 / 0,66	70	Fig.1	Fig.A	√ **	-
00001199	28 VDC	9500	12	0,4	2,2	0,3 / 0,66	70	Fig.1	Fig.A	-	√
00001200	28 VDC	9500	12	0,4	2,2	0,3 / 0,66	70	Fig.2	Fig.A	√ **	-
00001201	28 VDC	9500	12	0,4	2,2	0,3 / 0,66	70	Fig.2	Fig.A	-	√
00001202	28 VDC	9500	12	0,4	2,2	0,3 / 0,66	70	Fig.3	Fig.A	√ **	-
00001203	28 VDC	9500	12	0,4	2,2	0,3 / 0,66	70	Fig.3	Fig.A	-	√
00000941	28 VDC	9500	12	0,4	2,2	0,3 / 0,66	70	Fig.4	Fig.A	√ **	-
00001204	28 VDC	9500	12	0,4	2,2	0,3 / 0,66	70	Fig.4	Fig.A	-	√
00001205	28 VDC	11000	21	0,8	2,2	0,3 / 0,66	73	Fig.1	Fig.B	√ **	-
00001206	28 VDC	11000	21	0,8	2,2	0,3 / 0,66	73	Fig.1	Fig.B	-	√
00001207	28 VDC	11000	21	0,8	2,2	0,3 / 0,66	73	Fig.2	Fig.B	√ **	-
00001208	28 VDC	11000	21	0,8	2,2	0,3 / 0,66	73	Fig.2	Fig.B	-	√
00001209	28 VDC	11000	21	0,8	2,2	0,3 / 0,66	73	Fig.3	Fig.B	√ **	-
00001210	28 VDC	11000	21	0,8	2,2	0,3 / 0,66	73	Fig.3	Fig.B	-	√
00001129	28 VDC	11000	21	0,8	2,2	0,3 / 0,66	73	Fig.4	Fig.B	√ *	-
00001211	28 VDC	11000	21	0,8	2,2	0,3 / 0,66	73	Fig.4	Fig.B	-	√
00001212	28 VDC	15000	48	1,4	7	0,35 / 0,77	80	Fig.2	Fig.C	√ **	-
00001213	28 VDC	15000	48	1,4	7	0,35 / 0,77	80	Fig.2	Fig.C	-	√
00001141	28 VDC	15000	48	1,4	7	0,35 / 0,77	80	Fig.4	Fig.C	√ **	-
00001214	28 VDC	15000	48	1,4	7	0,35 / 0,77	80	Fig.4	Fig.C	-	√
00001215	28 VDC	18000	84	3	7	0,35 / 0,77	84	Fig.2	Fig.D	√ **	-
00001216	28 VDC	18000	84	3	7	0,35 / 0,77	84	Fig.3	Fig.D	-	√
00001217	28 VDC	18000	84	3	7	0,35 / 0,77	84	Fig.4	Fig.D	√ **	-
00001218	28 VDC	18000	84	3	7	0,35 / 0,77	84	Fig.4	Fig.D	-	√
00001219	28 VDC	20000	118	4,2	7	0,35 / 0,77	87	Fig.2	Fig.E	√ **	-
00001220	28 VDC	20000	118	4,2	7	0,35 / 0,77	87	Fig.2	Fig.E	-	√
00001221	28 VDC	20000	118	4,2	7	0,35 / 0,77	87	Fig.4	Fig.E	√ **	-
00001222	28 VDC	20000	118	4,2	7	0,35 / 0,77	87	Fig.4	Fig.E	-	√
00001223	28 VDC	22000	120	4,3	7	0,35 / 0,77	90	Fig.2	Fig.F	√ **	-
00001224	28 VDC	22000	120	4,3	7	0,35 / 0,77	90	Fig.2	Fig.F	-	√
00001225	28 VDC	22000	120	4,3	7	0,35 / 0,77	90	Fig.4	Fig.F	√ **	-
00001226	28 VDC	22000	120	4,3	7	0,35 / 0,77	90	Fig.4	Fig.F	-	√
00001264	28 VDC	22000	120	4,3	7	0,35 / 0,77	90	Fig.5	Fig.F	-	√

* Refer to page 38 «speed signal», FPS: type 2 / ** Refer to page 38 «speed signal», FPS: type 1 / Refer to page 42 «accessories»

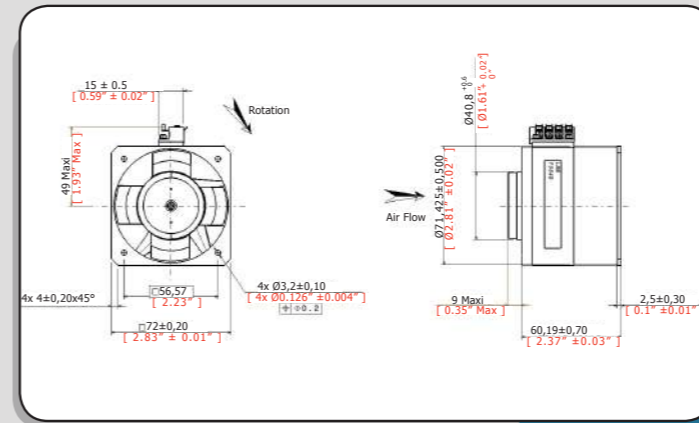

Fig.1

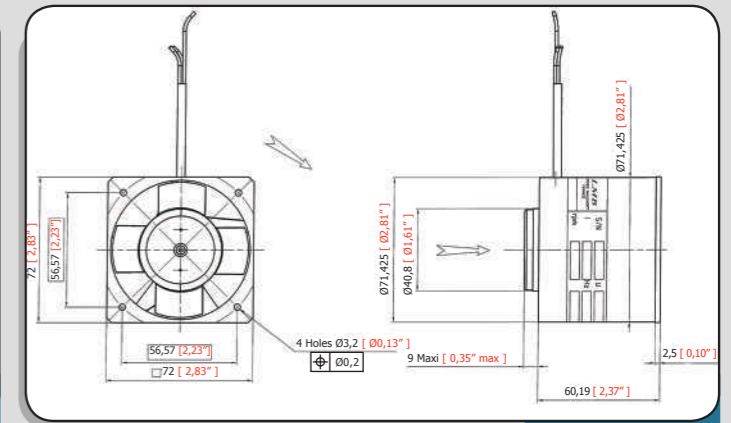

Fig.2

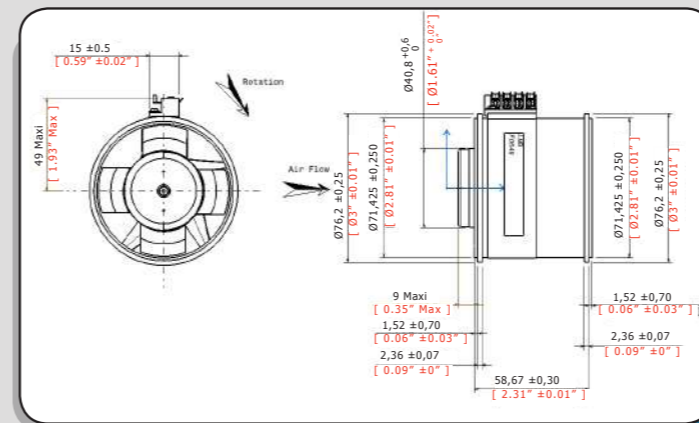

Fig.3

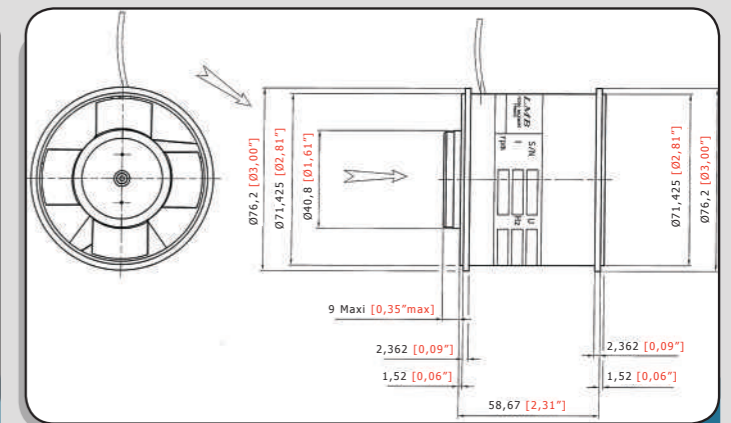

Fig.4

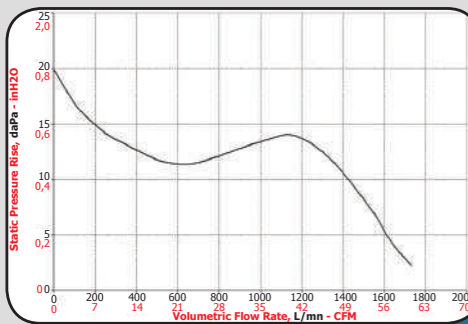

Fig.A

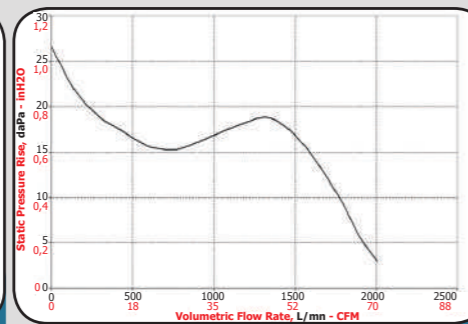

Fig.B

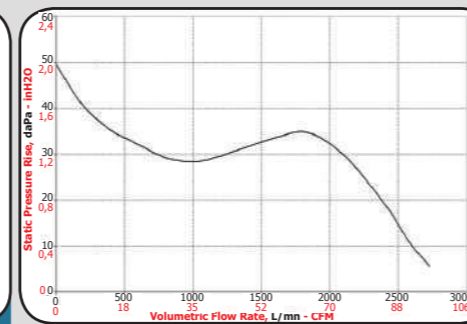

Fig.C

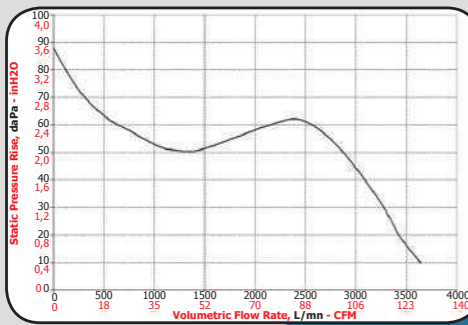

Fig.D

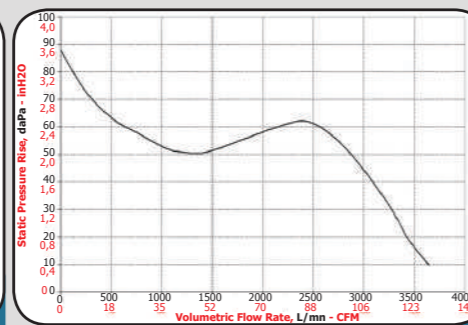

Fig.E

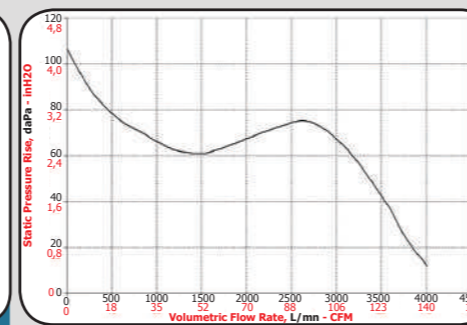

Fig.F

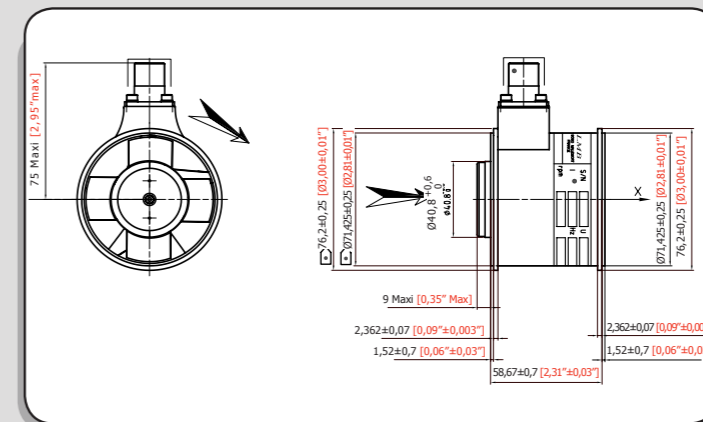

Fig.5

Part Number	Power Supply	Speed (rpm)	Input Power (Watts)	Input Current (Amps)	Starting Current (Amps)	Weight (Kg/Lbs)	Noise (dB(A))	Drawing	Curve	Speed Signal+ F.P.S	L.S.W	Speed Control** PWM
00-85001438-001	28 VDC	8400	5	0,18	2,2	0,22 / 0,48	57	Fig.5	Fig.A	-	✓	-
00001227	28 VDC	10000	7	0,25	2,2	0,17 / 0,38	60	Fig.1	Fig.B	✓	-	-
00001228	28 VDC	10000	7	0,25	2,2	0,17 / 0,38	60	Fig.1	Fig.B	-	✓	-
00001229	28 VDC	10000	7	0,25	2,2	0,17 / 0,38	60	Fig.2	Fig.B	✓	-	-
00001230	28 VDC	10000	7	0,25	2,2	0,17 / 0,38	60	Fig.2	Fig.B	-	✓	-
00001231	28 VDC	10000	7	0,25	2,2	0,17 / 0,38	60	Fig.3	Fig.B	✓	-	-
00001232	28 VDC	10000	7	0,25	2,2	0,17 / 0,38	60	Fig.3	Fig.B	-	✓	-
00001139	28 VDC	10000	7	0,25	2,2	0,17 / 0,38	60	Fig.4	Fig.B	✓	-	-
00001233	28 VDC	10000	7	0,25	2,2	0,17 / 0,38	60	Fig.4	Fig.B	-	✓	-
00-85001416-001	28 VDC	10000	7	0,25	2,2	0,22 / 0,48	60	Fig.5	Fig.B	✓	-	-
00-85001409-001	28 VDC	10000	7	0,25	2,2	0,22 / 0,48	60	Fig.5	Fig.B	-	✓	-
00001103	28 VDC	12000	11	0,4	2,2	0,17 / 0,38	64	Fig.1	Fig.C	✓	-	-
00001234	28 VDC	12000	11	0,4	2,2	0,17 / 0,38	64	Fig.1	Fig.C	-	✓	-
00001235	28 VDC	12000	11	0,4	2,2	0,17 / 0,38	64	Fig.2	Fig.C	✓	-	-
00001236	28 VDC	12000	11	0,4	2,2	0,17 / 0,38	64	Fig.2	Fig.C	-	✓	-
00001237	28 VDC	12000	11	0,4	2,2	0,17 / 0,38	64	Fig.3	Fig.C	✓	-	-
00001238	28 VDC	12000	11	0,4	2,2	0,17 / 0,38	64	Fig.3	Fig.C	-	✓	-
00001239	28 VDC	12000	11	0,4	2,2	0,17 / 0,38	64	Fig.4	Fig.C	✓	-	-
00001240	28 VDC	12000	11	0,4	2,2	0,17 / 0,38	64	Fig.4	Fig.C	-	✓	-
00001241	28 VDC	22000	40	1,4	2,2	0,17 / 0,38	77	Fig.1	Fig.D	✓	-	-
00001242	28 VDC	22000	40	1,4	2,2	0,17 / 0,38	77	Fig.1	Fig.D	-	✓	-
00001243	28 VDC	22000	40	1,4	2,2	0,17 / 0,38	77	Fig.2	Fig.D	✓	-	-
00001244	28 VDC	22000	40	1,4	2,2	0,17 / 0,38	77	Fig.2	Fig.D	-	✓	-
00001245	28 VDC	22000	40	1,4	2,2	0,17 / 0,38	77	Fig.3	Fig.D	✓	-	-
00001246	28 VDC	22000	40	1,4	2,2	0,17 / 0,38	77	Fig.3	Fig.D	-	✓	-
00001118	28 VDC	22000	40	1,4	2,2	0,17 / 0,38	77	Fig.4	Fig.D	✓	-	-
00001102	28 VDC	22000	40	1,4	2,2	0,17 / 0,38	77	Fig.4	Fig.D	-	✓	-
00-85001385-001	28 VDC	22000	40	1,4	2,2	0,22 / 0,48	77	Fig.5	Fig.D	-	✓	-
00-85001454-001	28 VDC	22000	40	1,4	2,2	0,17 / 0,38	77	Fig.4	Fig.D	✓	-	✓

* Refer to page 38 «speed signal», FPS: type 2 / ** Refer to page 39 «PWM» / Refer to page 42 «accessories»

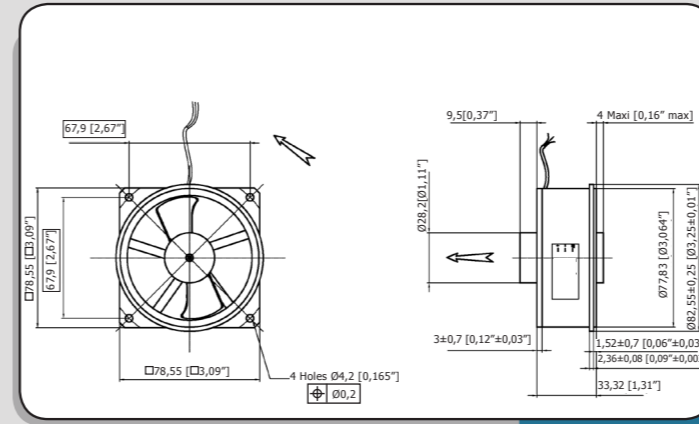

Fig.1

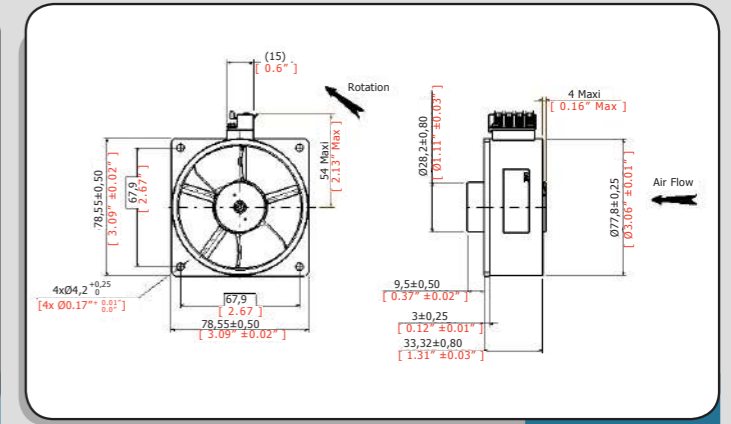

Fig.2

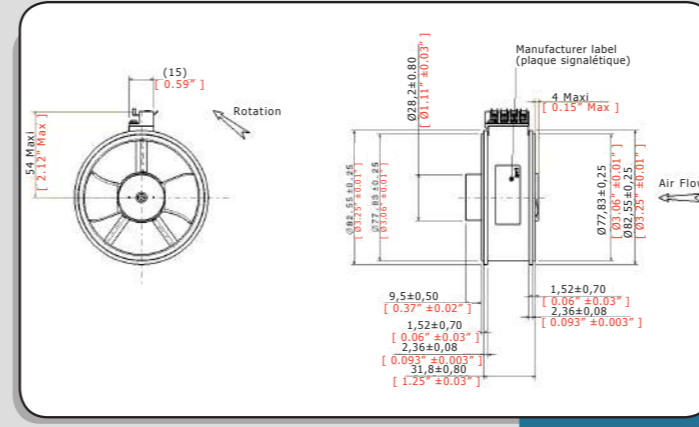

Fig.3

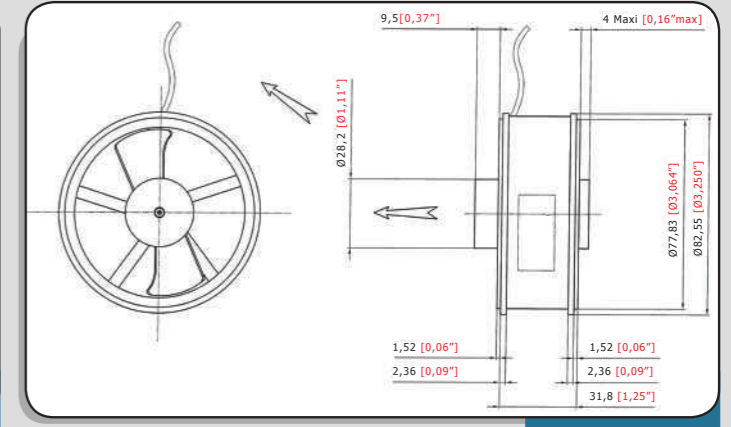

Fig.4

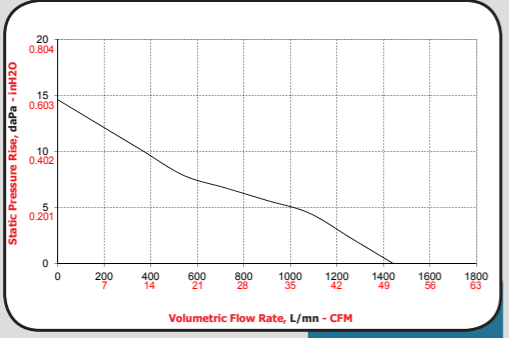

Fig.A

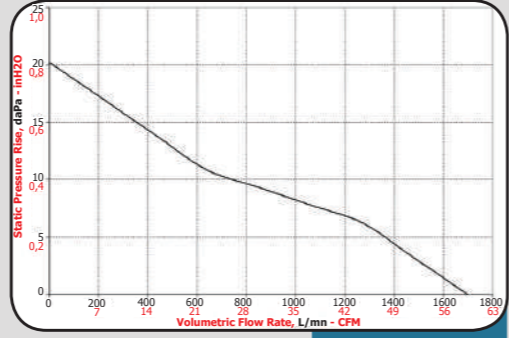

Fig.B

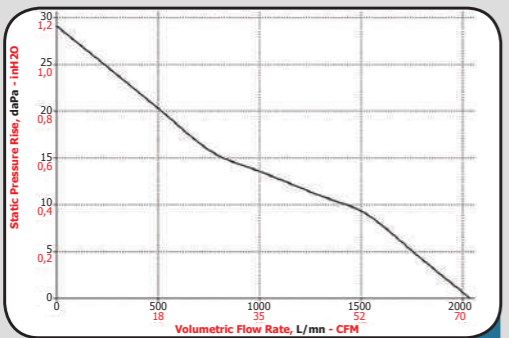

Fig.C

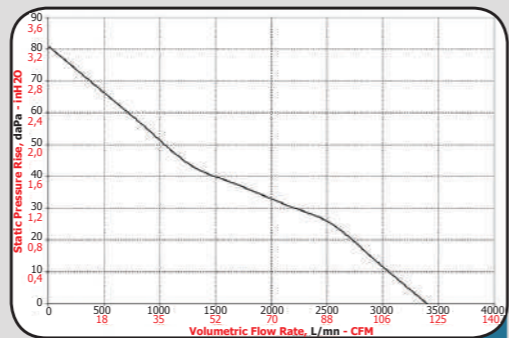

Fig.D

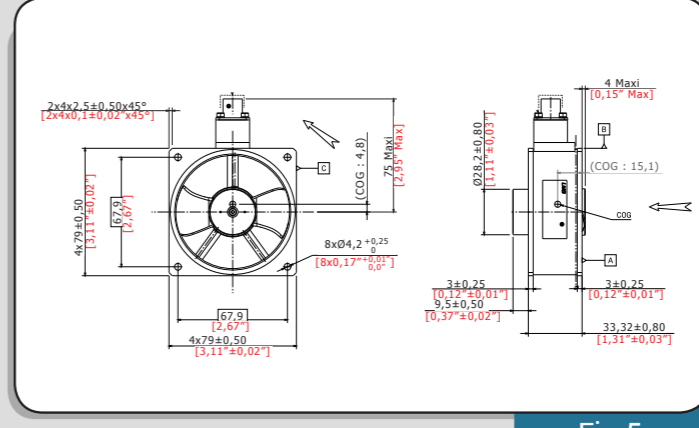

Fig.5

Part Number	Power Supply	Speed (rpm)	Input Power (Watts)	Input Current (Amps)	Starting Current (Amps)	Weight (Kg/Lbs)	Noise (dB(A))	Drawing	Curve	Speed Signal+/**	
										F.P.S	L.S.W
00001247	26 VDC	6800	18	0,6	3	0,38 / 0,84	62	Fig.1	Fig.A	√*	-
00-85001455-001	26 VDC	6800	18	0,6	3	0,38 / 0,84	62	Fig.1	Fig.A	-	√
00001248	26 VDC	6800	18	0,6	3	0,38 / 0,84	62	Fig.2	Fig.A	√*	-
00-85001456-001	26 VDC	6800	18	0,6	3	0,38 / 0,84	62	Fig.2	Fig.A	-	√
00001249	26 VDC	6800	18	0,6	3	0,38 / 0,84	62	Fig.3	Fig.A	√*	-
00-85001457-001	26 VDC	6800	18	0,6	3	0,38 / 0,84	62	Fig.3	Fig.A	-	√
00000974	26 VDC	6800	18	0,6	3	0,38 / 0,84	62	Fig.4	Fig.A	√*	-
00-85001458-001	26 VDC	6800	18	0,6	3	0,38 / 0,84	62	Fig.4	Fig.A	-	√
00001250	28 VDC	8600	30	1,1	3	0,38 / 0,84	66	Fig.1	Fig.B	√*	-
00-85001459-001	28 VDC	8600	30	1,1	3	0,38 / 0,84	66	Fig.1	Fig.B	-	√
00001251	28 VDC	8600	30	1,1	3	0,38 / 0,84	66	Fig.2	Fig.B	√*	-
00-85001460-001	28 VDC	8600	30	1,1	3	0,38 / 0,84	66	Fig.2	Fig.B	-	√
00001252	28 VDC	8600	30	1,1	3	0,38 / 0,84	66	Fig.3	Fig.B	√*	-
00-85001461-001	28 VDC	8600	30	1,1	3	0,38 / 0,84	66	Fig.3	Fig.B	-	√
00001026	28 VDC	8600	30	1,1	3	0,38 / 0,84	66	Fig.4	Fig.B	√*	-
00-85001462-001	28 VDC	8600	30	1,1	3	0,38 / 0,84	66	Fig.4	Fig.B	-	√
00-85001344-001	28VDC	8600	30	1,1	3	0,38 / 0,84	66	Fig.5	Fig.B	√	-
00-85001401-001	28VDC	10000	45	1,6	3	0,38 / 0,84	68	Fig.5	Fig.C	√	-
00001148	28 VDC	15000	126	4,5	7	0,42 / 0,93	80	Fig.6	Fig.D	√**	-
00001101	28 VDC	15000	126	4,5	7	0,42 / 0,93	80	Fig.6	Fig.D	-	√
00001253	28 VDC	15000	126	4,5	7	0,42 / 0,93	80	Fig.7	Fig.D	√**	-
00001254	28 VDC	15000	126	4,5	7	0,42 / 0,93	80	Fig.7	Fig.D	-	√
00-85001346-001	28 VDC	16000	182	6,5	10	0,42 / 0,93	80	Fig.6	Fig.E	√**	-
00-85001347-001	28 VDC	16000	182	6,5	10	0,42 / 0,93	80	Fig.6	Fig.E	-	√
00-85001348-001	28 VDC	16000	182	6,5	10	0,42 / 0,93	80	Fig.7	Fig.E	√**	-
00-85001349-001	28 VDC	16000	182	6,5	10	0,42 / 0,93	80	Fig.7	Fig.E	-	√

* Refer to page 38 «speed signal», FPS: type 3

** Refer to page 38 «speed signal», FPS: type 1 / Refer to page 42 «accessories»

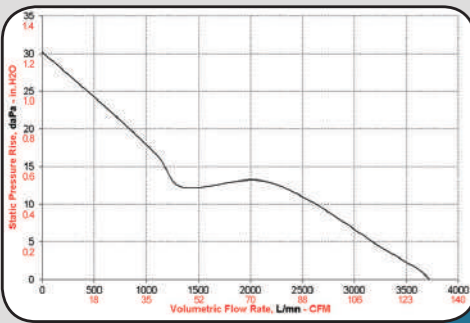

Fig.A

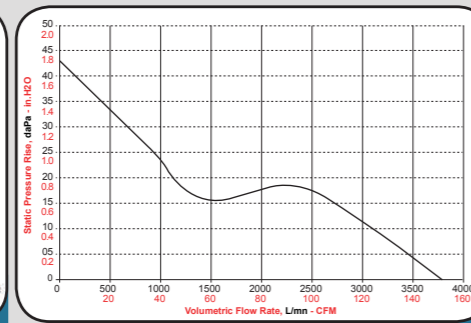

Fig.B

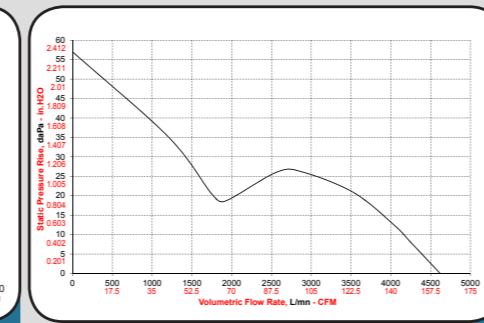

Fig.C

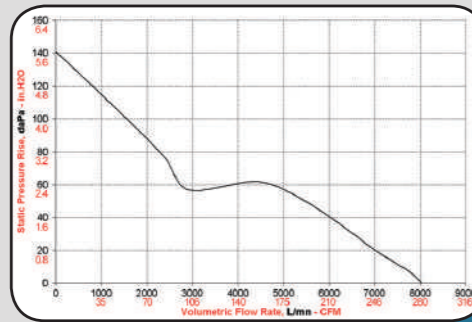

Fig.D

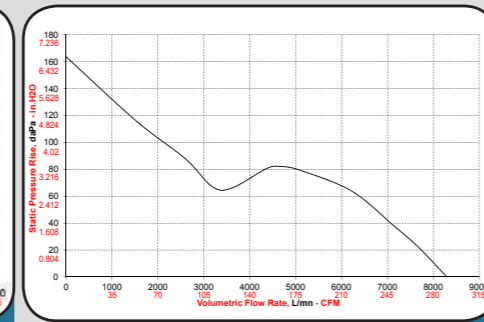

Fig.E

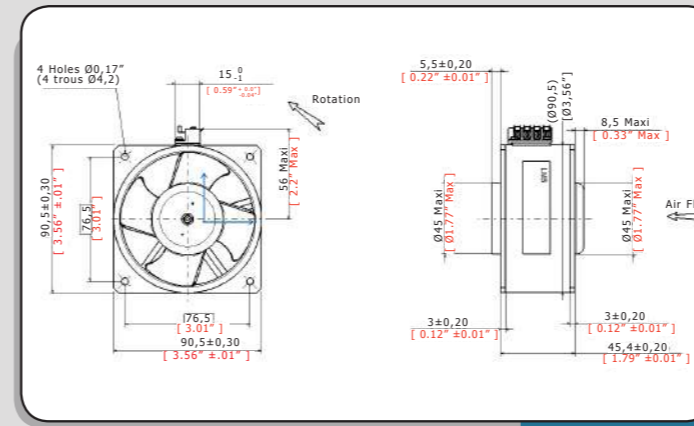

Fig.1

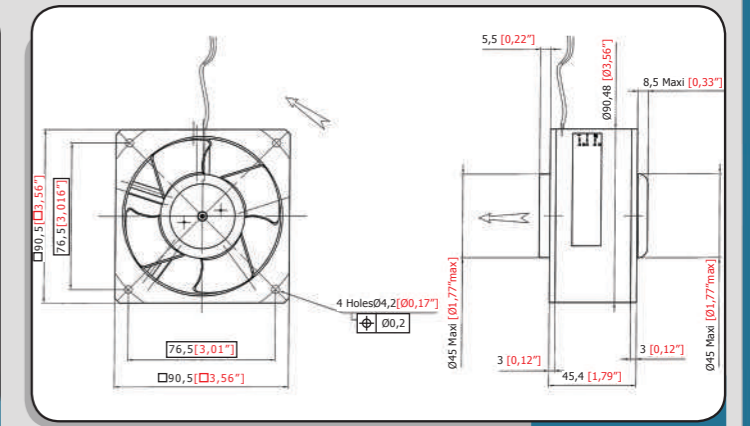

Fig.2

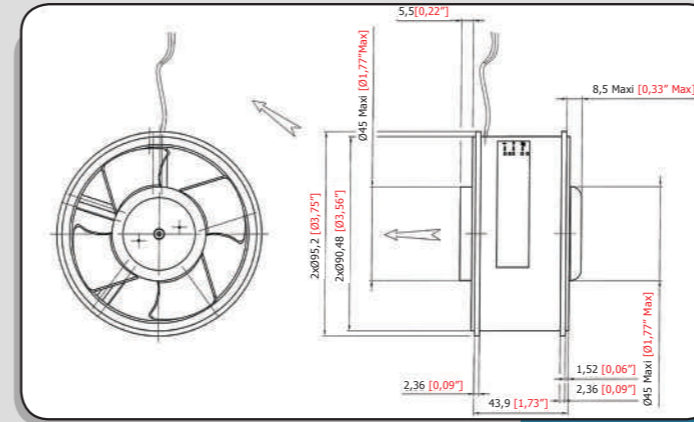

Fig.3

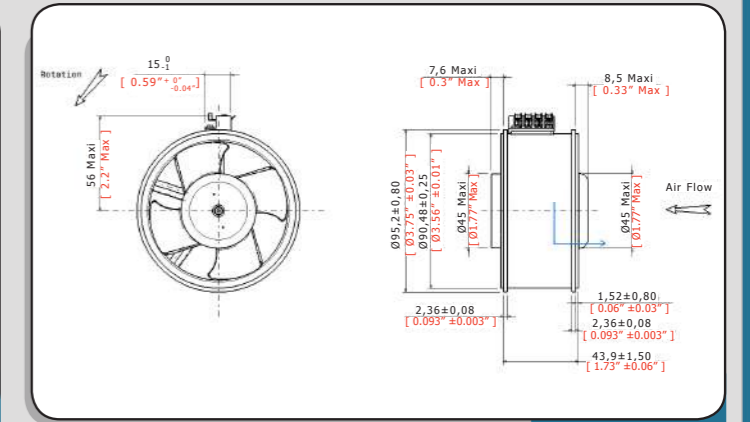

Fig.4

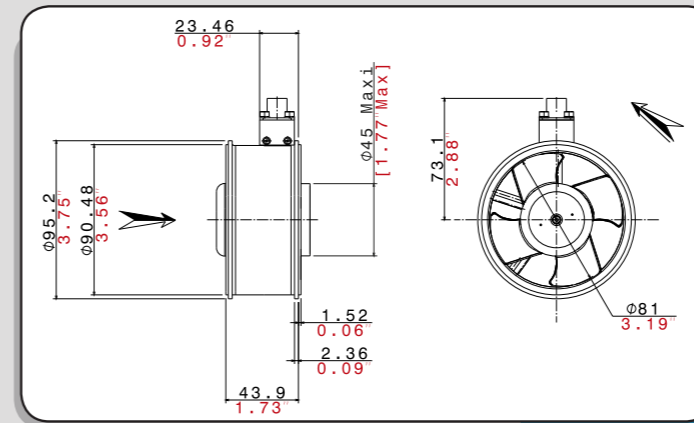

Fig.5

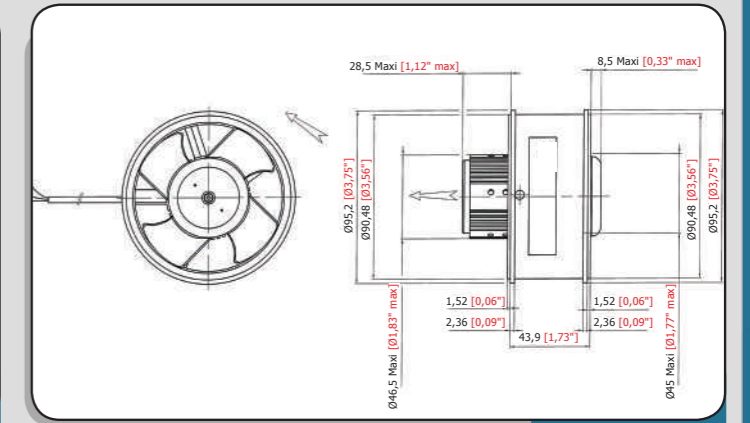

Fig.6

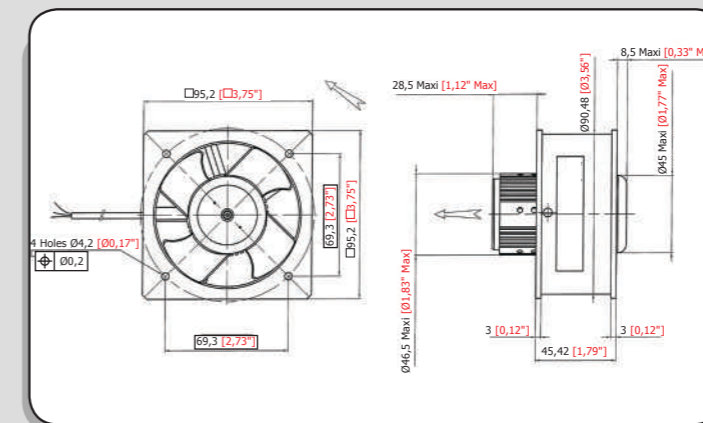

Fig.7

Part Number	Power Supply	Speed (rpm)	Input Power (Watts)	Input Current (Amps)	Starting Current (Amps)	Weight (Kg/Lbs)	Noise (dB(A))	Drawing	Curve	Speed Signal*/**	
										F.P.S	L.S.W
00-85001465-001	24	4800	44	2,0	3	1.0 / 2.2	73	Fig.1	Fig.A	✓	-
00-85001466-001	24	4800	44	2,0	3	1.0 / 2.2	73	Fig.1	Fig.A	-	✓
00-85001467-001	24	4800	44	2,0	3	1.0 / 2.2	73	Fig.2	Fig.A	✓	-
00-85001468-001	24	4800	44	2,0	3	1.0 / 2.2	73	Fig.2	Fig.A	-	✓
00-85001469-001	24	4800	44	2,0	3	1.0 / 2.2	73	Fig.3	Fig.A	✓	-
00-85001470-001	24	4800	44	2,0	3	1.0 / 2.2	73	Fig.3	Fig.A	-	✓
00-85001471-001	24	4800	44	2,0	3	1.0 / 2.2	73	Fig.4	Fig.A	✓	-
00-85001472-001	24	4800	44	2,0	3	1.0 / 2.2	73	Fig.4	Fig.A	-	✓
00-85001473-001	24	5500	70	2,8	3	1.0 / 2.2	76	Fig.1	Fig.B	✓	-
00-85001474-001	24	5500	70	2,8	3	1.0 / 2.2	76	Fig.1	Fig.B	-	✓
00-85001475-001	24	5500	70	2,8	3	1.0 / 2.2	76	Fig.2	Fig.B	✓	-
00-85001476-001	24	5500	70	2,8	3	1.0 / 2.2	76	Fig.2	Fig.B	-	✓
00-85001477-001	24	5500	70	2,8	3	1.0 / 2.2	76	Fig.3	Fig.B	✓	-
00-85001478-001	24	5500	70	2,8	3	1.0 / 2.2	76	Fig.3	Fig.B	-	✓
00-85001479-001	24	5500	70	2,8	3	1.0 / 2.2	76	Fig.4	Fig.B	✓	-
00-85001480-001	24	5500	70	2,8	3	1.0 / 2.2	76	Fig.4	Fig.B	-	✓
00-85001481-001	28	3000	18	0,6	3	1.0 / 2.2	63	Fig.1	Fig.C	✓	-
00-85001482-001	28	3000	18	0,6	3	1.0 / 2.2	63	Fig.1	Fig.C	-	✓
00-85001483-001	28	3000	18	0,6	3	1.0 / 2.2	63	Fig.2	Fig.C	✓	-
00-85001484-001	28	3000	18	0,6	3	1.0 / 2.2	63	Fig.2	Fig.C	-	✓
00-85001485-001	28	3000	18	0,6	3	1.0 / 2.2	63	Fig.3	Fig.C	✓	-
00-85001486-001	28	3000	18	0,6	3	1.0 / 2.2	63	Fig.3	Fig.C	-	✓
00-85001487-001	28	3000	18	0,6	3	1.0 / 2.2	63	Fig.4	Fig.C	✓	-
00-85001488-001	28	3000	18	0,6	3	1.0 / 2.2	63	Fig.4	Fig.C	-	✓
00-85001489-001	28	4500	41	1,6	3	1.0 / 2.2	72	Fig.1	Fig.D	✓	-
00-85001490-001	28	4500	41	1,6	3	1.0 / 2.2	72	Fig.1	Fig.D	-	✓
00-85001491-001	28	4500	41	1,6	3	1.0 / 2.2	72	Fig.2	Fig.D	✓	-
00-85001492-001	28	4500	41	1,6	3	1.0 / 2.2	72	Fig.2	Fig.D	-	✓
00-85001493-001	28	4500	41	1,6	3	1.0 / 2.2	72	Fig.3	Fig.D	✓	-
00-85001494-001	28	4500	41	1,6	3	1.0 / 2.2	72	Fig.3	Fig.D	-	✓
00-85001495-001	28	4500	41	1,6	3	1.0 / 2.2	72	Fig.4	Fig.D	✓	-
00-85001496-001	28	4500	41	1,6	3	1.0 / 2.2	72	Fig.4	Fig.D	-	✓
00-85001497-001	28	6000	87	3,5	7	1.0 / 2.2	78	Fig.1	Fig.E	✓	-
00-85001498-001	28	6000	87	3,5	7	1.0 / 2.2	78	Fig.1	Fig.E	-	✓
00-85001499-001	28	6000	87	3,5	7	1.0 / 2.2	78	Fig.2	Fig.E	✓	-
00-85001500-001	28	6000	87	3,5	7	1.0 / 2.2	78	Fig.2	Fig.E	-	✓
00-85001501-001	28	6000	87	3,5	7	1.0 / 2.2	78	Fig.3	Fig.E	✓	-
00-85001502-001	28	6000	87	3,5	7	1.0 / 2.2	78	Fig.3	Fig.E	-	✓
00-85001503-001	28	6000	87	3,5	7	1.0 / 2.2	78	Fig.4	Fig.E	✓	-
00-85001504-001	28	6000	87	3,5	7	1.0 / 2.2	78	Fig.4	Fig.E	-	✓

* Refer to page 38 «speed signal», FPS: type 4 / Refer to page 42 «accessories»

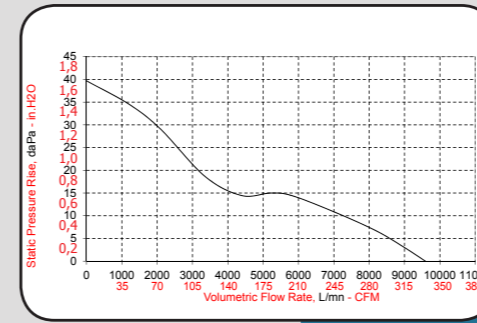

Fig.A

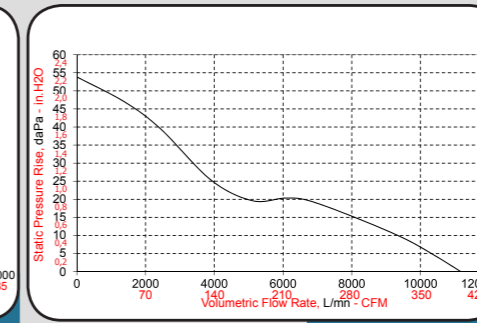

Fig.B

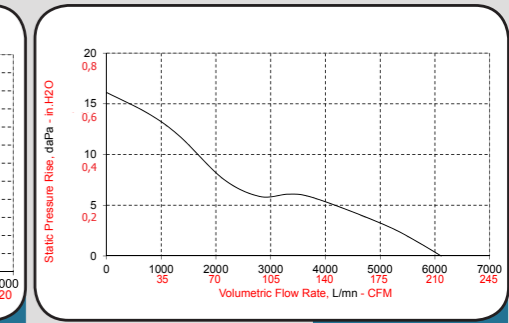

Fig.C

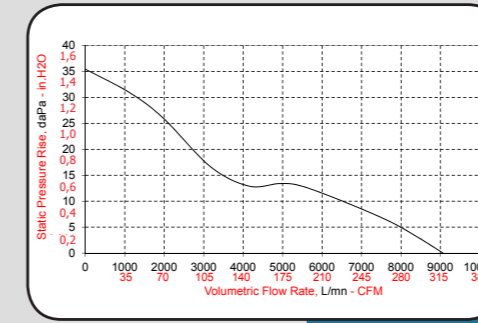

Fig.D

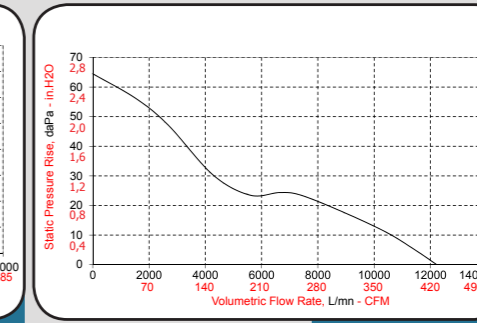

Fig.E

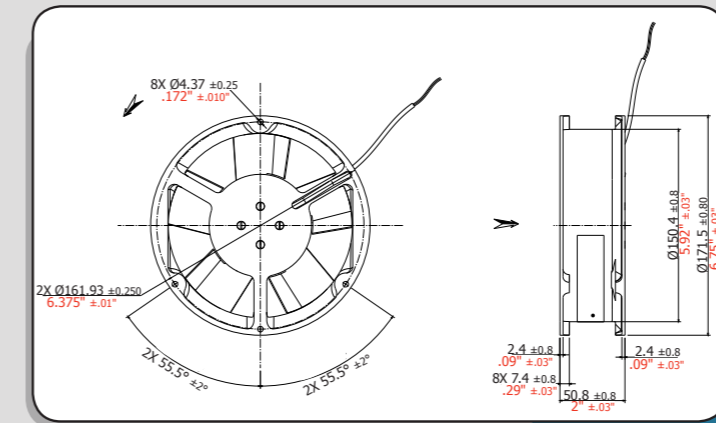

Fig.1

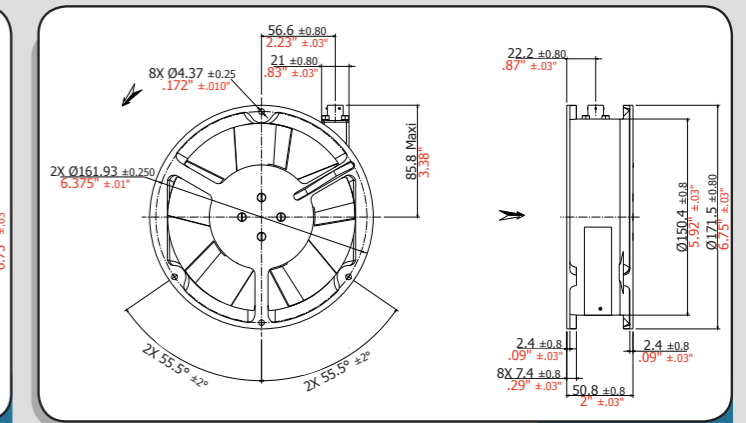

Fig.2

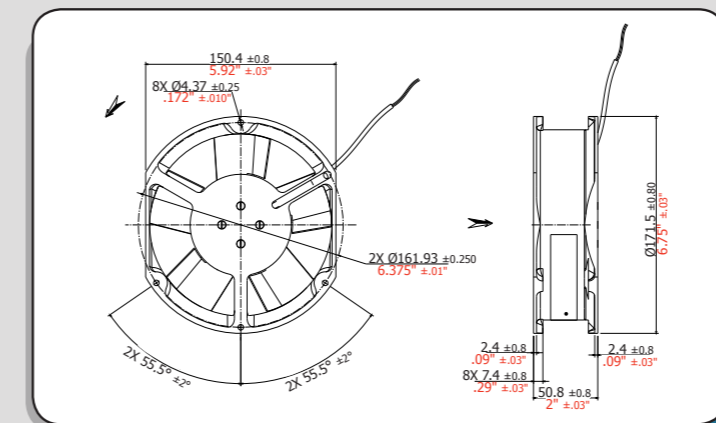

Fig.3

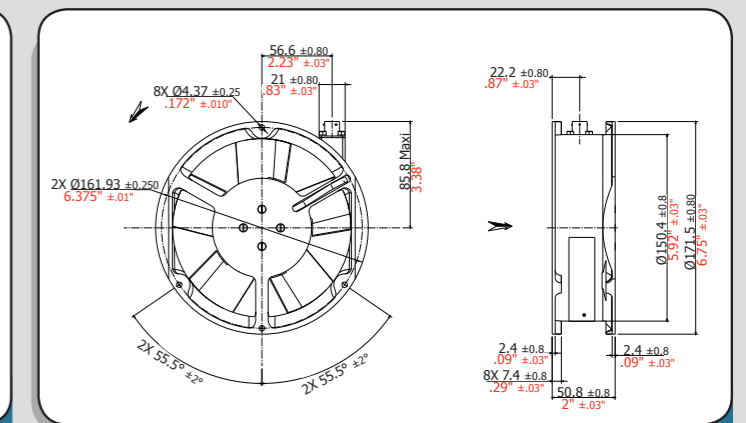

Fig.4

Part Number	Power Supply	Speed (rpm)	Input Power (Watts)	Input Current (Amps)	Starting Current (Amps)	Weight (Kg/Lbs)	Noise (dB(A))	Drawing	Curve	Speed Signal*/**	
										F.P.S	L.S.W
00-85001617-001	28 VDC	9000	17	0,6	2,5	0,62 / 1,37	73	Fig.1	Fig.A	✓	-
00-85001522-001	28 VDC	12000	62	2,2	5	0,62 / 1,37	79	Fig.1	Fig.B	✓	-
00-85001523-001	28 VDC	16000	155	5,5	7	0,62 / 1,37	85	Fig.1	Fig.C	✓	-

* Refer to page 38 «speed signal», FPS: type 6 / Refer to page 42 «accessories»

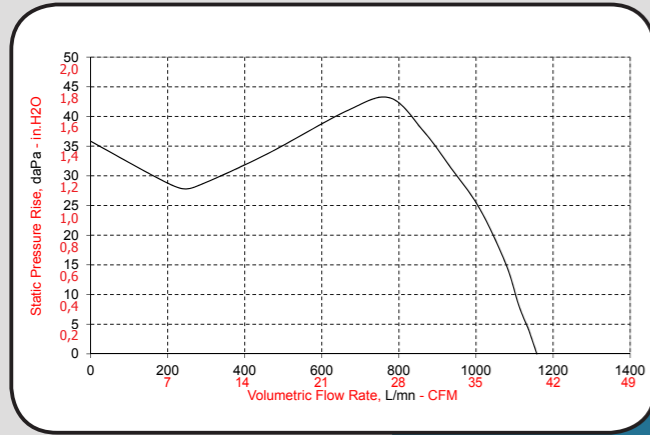

Fig.A

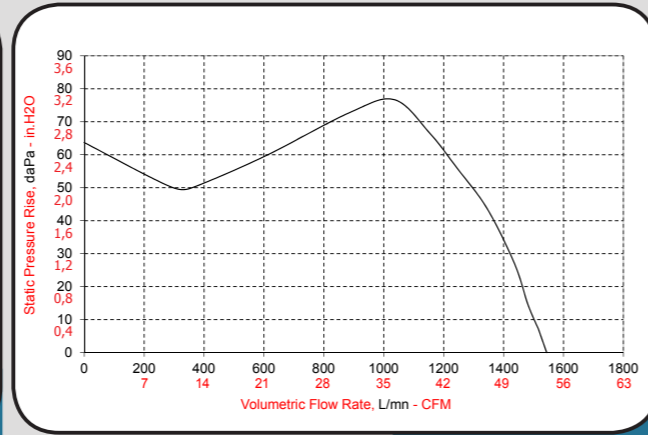

Fig.B

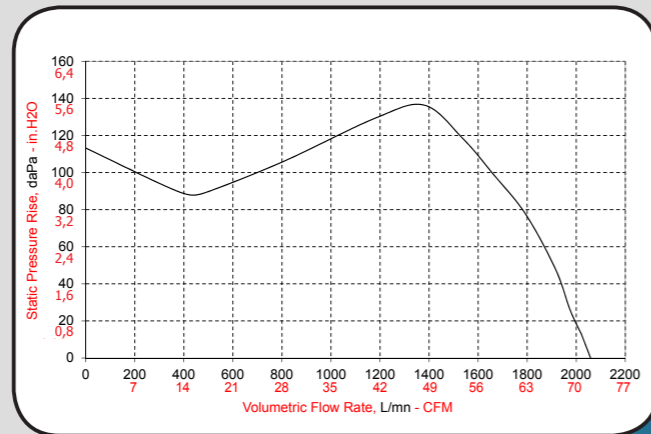

Fig.C

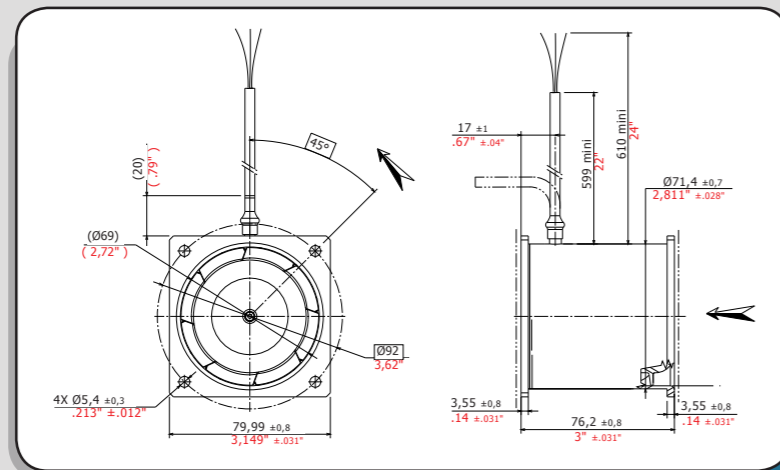

Fig.1

AC 400Hz Fans

CUMIN

Part Number	Power Supply	Cap* (μF)	Speed (rpm)	Input Power (Watts)	Input Current (Amps)	Starting Current (Amps)	Weight (Kg/Lbs)	Noise (dB(A))	Drawing	Curve	Speed Signal	
											F.P.S	L.S.W
00000372	200V / 3 Phases / 400Hz	-	22000	8	0.05	0.07	0.05/0.11	52	Fig.1	Fig.A	-	-
00000373	115V / 3 Phases / 400Hz	-	22000	8	0.08	0.11	0.05/0.11	52	Fig.1	Fig.A	-	-
00000198	115V / 1 Phase / 400Hz	0.3	22000	8	0.08	0.11	0.05/0.11	52	Fig.1	Fig.A	-	-

* Capacitor (not supplied) : 150 VAC

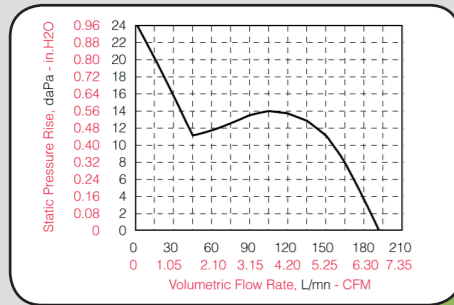

Fig.A

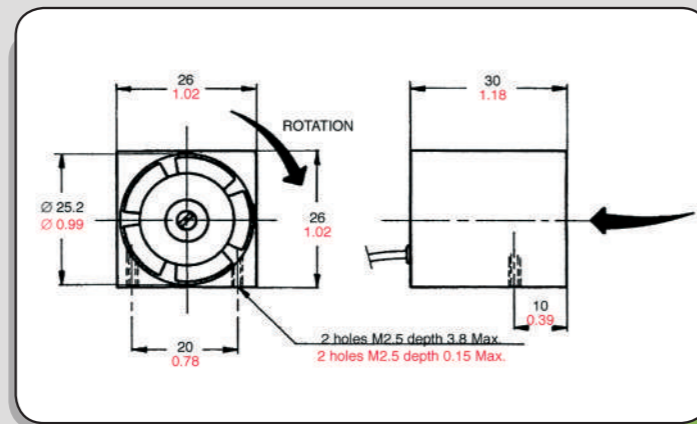

Fig.1

CHERI

Part Number	Power Supply	Cap (μF)	Speed (rpm)	Input Power (Watts)	Input Current (Amps)	Starting Current (Amps)	Weight (Kg/Lbs)	Noise (dB(A))	Drawing	Curve	Speed Signal	
											F.P.S	L.S.W
00000105	200V / 3 Phases / 400Hz	-	22000	11	0.05	0.1	0.07/0.14	58	Fig.1	Fig.A	-	-

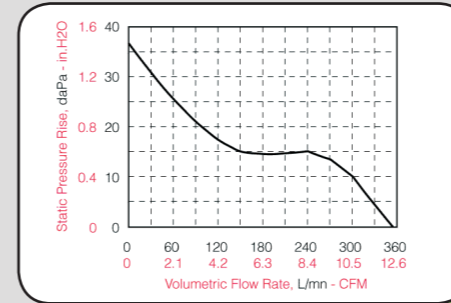

Fig.A

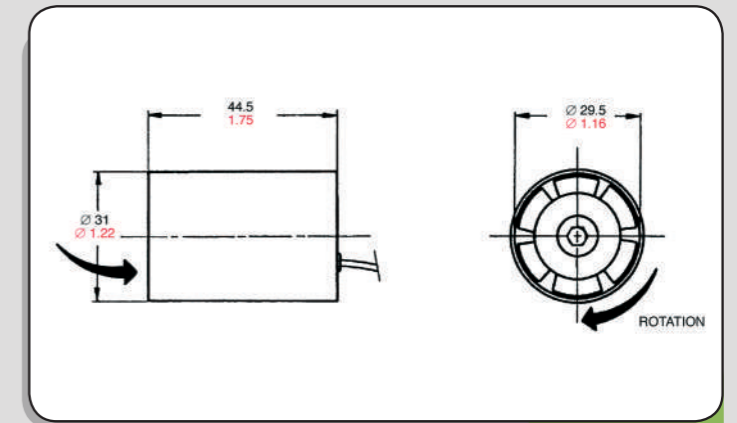

Fig.1

CANDI

Part Number	Power Supply	Cap* (μF)	Speed (rpm)	Input Power (Watts)	Input Current (Amps)	Starting Current (Amps)	Weight (Kg/Lbs)	Noise (dB(A))	Drawing	Curve	Speed Signal	
											F.P.S	L.S.W
00000169	200V / 3 Phases / 400Hz	-	21500	6	0.03	0.07	0.07/0.154	57	Fig.1	Fig.A	-	-
00001257	115V / 1 Phase / 400Hz		21500	6	0.33	0.75	0.07/0.154	57	Fig.1	Fig.A	-	-
00000311	20V / 1 Phase / 400Hz	0.3	21500	6	0.33	0.75	0.07/0.154	57	Fig.1	Fig.A	-	-

* Capacitor (not supplied) : 150 VAC

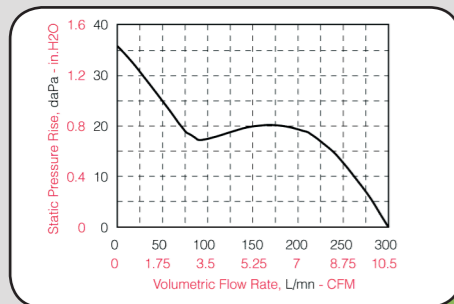

Fig.A

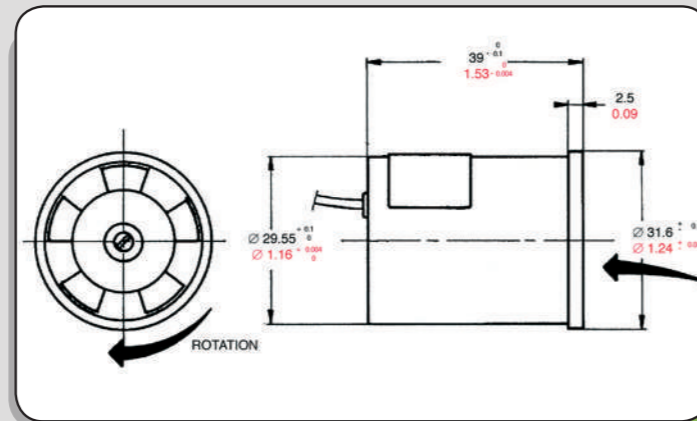

Fig.1

MORTIER-1

Part Number	Power Supply	Cap* (μF)	Speed (rpm)	Input Power (Watts)	Input Current (Amps)	Starting Current (Amps)	Weight (Kg/Lbs)	Noise (dB(A))	Drawing	Curve	Speed Signal	
											F.P.S	L.S.W
00000913	115V / 1 Phase / 400Hz	0.3	11000	10	0.05	0.1	0.1/0.22	55	Fig.1	Fig.A	-	-
00000955	200V / 3 Phases / 400Hz	-	22000	17	0.09	0.2	0.1/0.22	67	Fig.1	Fig.B	-	-
00000822	115V / 1 Phase / 400Hz	0.47	22000	16	0.17	0.4	0.1/0.22	67	Fig.1	Fig.B	-	-

* Capacitor (not supplied) : 150 VAC

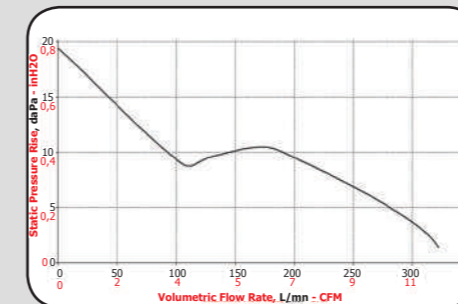

Fig.A

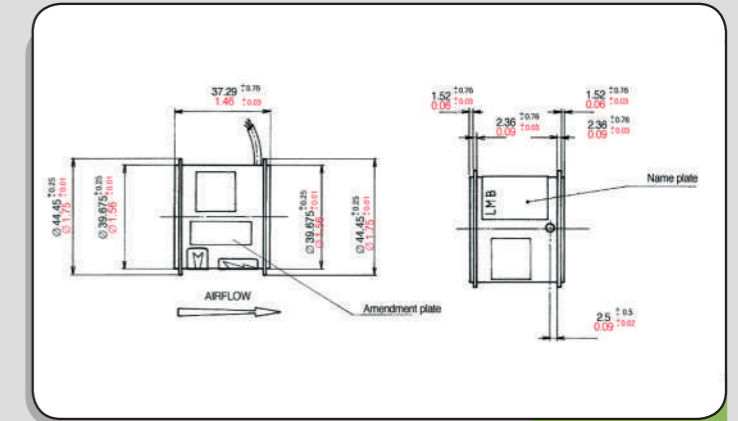

Fig.1

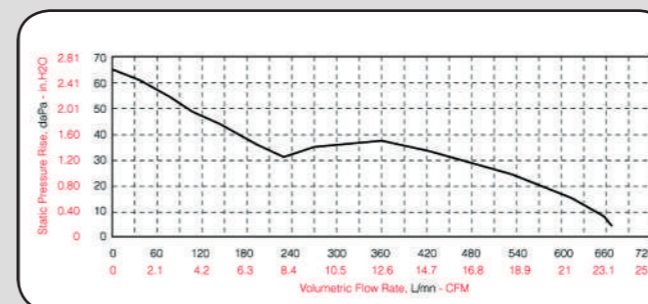

Fig.B

	Part Number	Power Supply	Cap** (μF)	Speed (rpm)	Input Power (Watts)	Input Current (Amps)	Starting Current (Amps)	Weight (Kg/Lbs)	Noise (dB(A))	Drawing	Curve	Speed Signal*	
												F.P.S	L.S.W
MAXIME 4	00000051	200V / 3 Phases / 400Hz	-	10500	10	0.05	0.07	0.1/0.22	55	Fig.1	Fig.A	-	-
	00000434	115V / 1 Phase / 400Hz	0.3	10500	10	0.09	0.11	0.1/0.22	55	Fig.1	Fig.A	-	-
	00000950	115V / 3 Phases / 400Hz	-	10500	10	0.09	0.11	0.1/0.22	55	Fig.1	Fig.A	-	-
MAXIME 2	00000046	200V / 3 Phases / 400Hz	-	21500	21	0.01	0.21	0.1/0.22	67	Fig.1	Fig.B	-	-
	00000949	115V / 1 Phase / 400Hz	0.47	21500	21	0.17	0.32	0.1/0.22	67	Fig.1	Fig.B	-	-
	00000428	115V / 3 Phases / 400Hz	-	21500	21	0.17	0.32	0.1/0.22	67	Fig.1	Fig.B	-	-
	00001087	200V / 3 Phases / 400Hz	-	21500	21	0.1	0.21	0.12/0.26	67	Fig.2	Fig.B	✓	-
	00000047	115V / 1 Phase / 400Hz	0.47	21500	21	0.17	0.32	0.12/0.26	67	Fig.2	Fig.B	✓	-

* Refer to page 38 «speed signal»
 ** Capacitor (not supplied) : 150 VAC

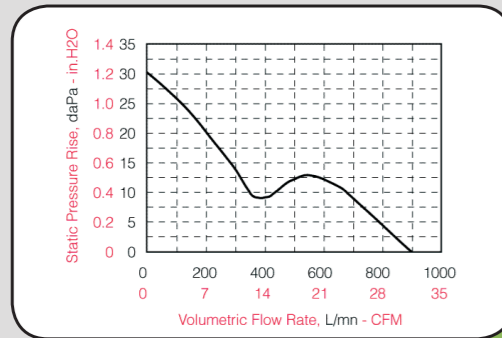

Fig.A

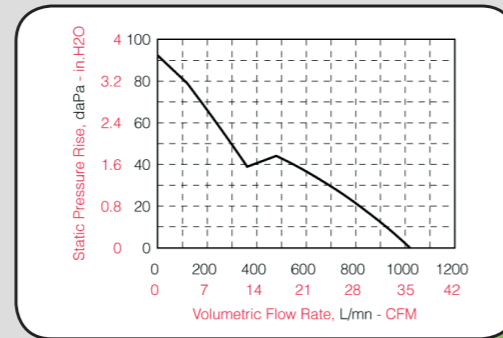

Fig.B

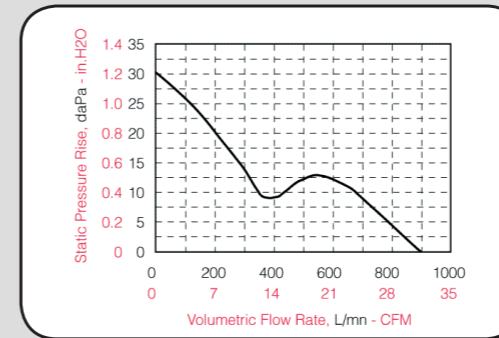

Fig.A

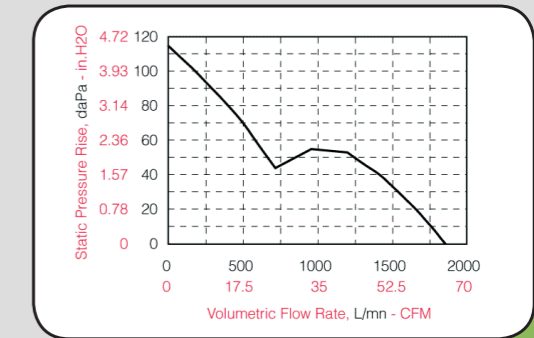

Fig.B

* Refer to page 38 «speed signal»
 ** Capacitor (not supplied) : 150 VAC

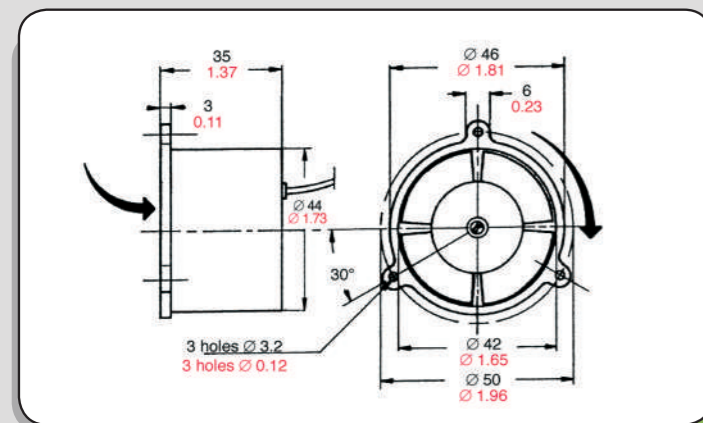

Fig.1

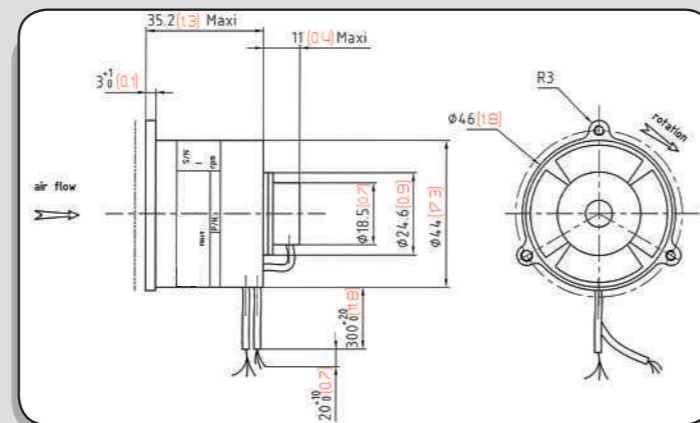

Fig.2

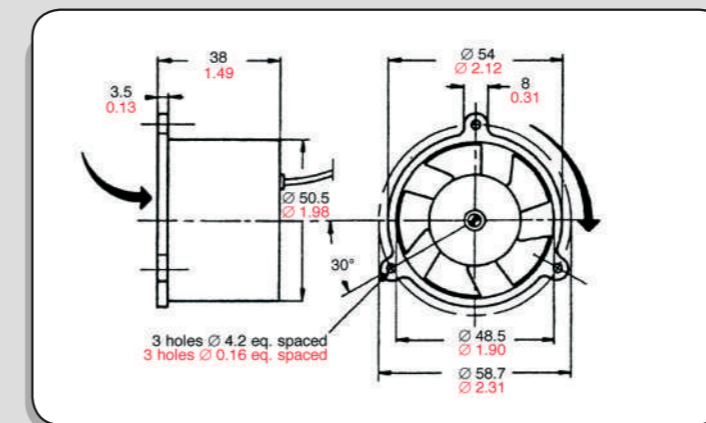

Fig.1

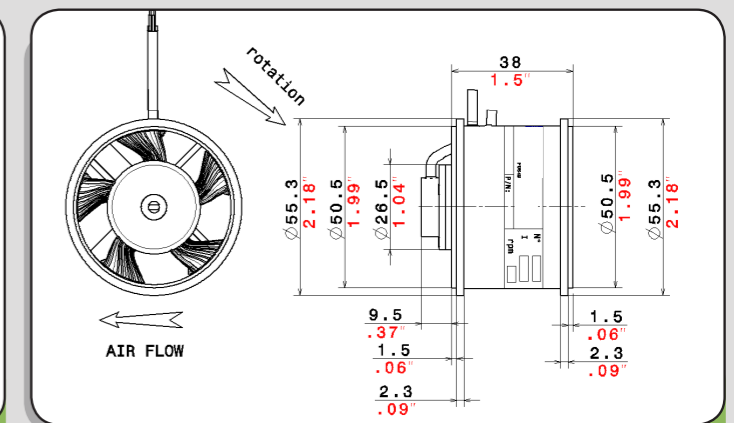

Fig.2

MARYLAND-1

Part Number	Power Supply	Cap* (µF)	Speed (rpm)	Input Power (Watts)	Input Current (Amps)	Starting Current (Amps)	Weight (Kg/Lbs)	Noise (dB(A))	Drawing	Curve	Speed Signal	
											F.P.S	L.S.W
00000986	200V / 3 Phases / 400Hz	-	21000	80	0.3	1	0.36/0.8	80	Fig.1	Fig.A	-	-
00000985	115V / 1 Phase / 400Hz	1	21000	80	0.6	1.45	0.36/0.8	80	Fig.1	Fig.A	-	-

* Capacitor (not supplied) : 150 VAC

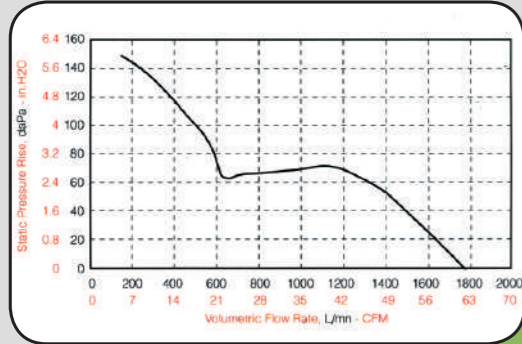

Fig.A

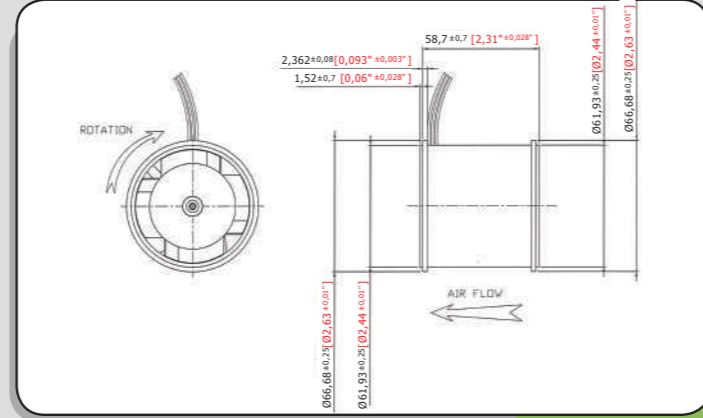

Fig.1

MEDIA 2P5

Part Number	Power Supply	Cap* (µF)	Speed (rpm)	Input Power (Watts)	Input Current (Amps)	Starting Current (Amps)	Weight (Kg/Lbs)	Noise (dB(A))	Drawing	Curve	Speed Signal	
											F.P.S	L.S.W
00000729	200V / 3 Phases / 400Hz	-	21500	190	0.65	2.5	0.42/0.94	88	Fig.1	Fig.A	-	-
00000523	115V / 1 Phase / 400Hz	1.5	21500	230	1.7	4.1	0.42/0.94	88	Fig.1	Fig.A	-	-

* Capacitor (not supplied) : 150 VAC

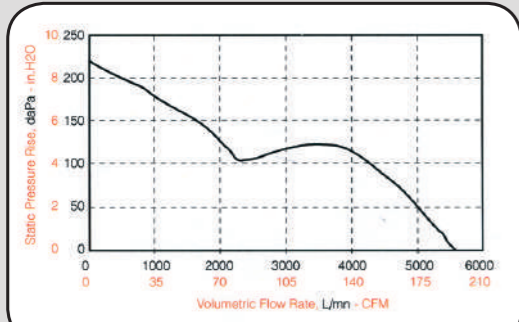

Fig.A

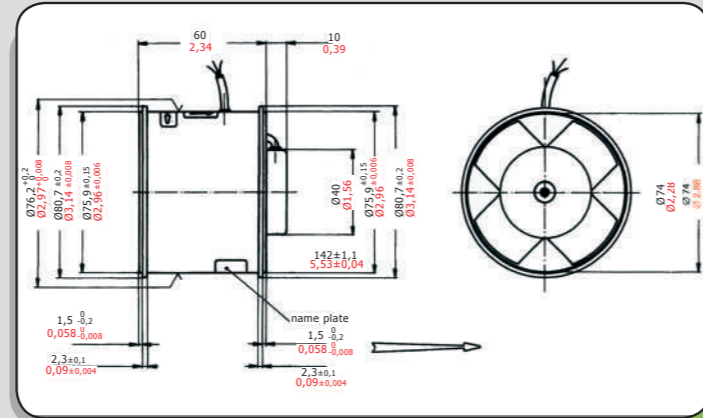

Fig.1

MERCATOR

Part Number	Power Supply	Cap* (µF)	Speed (rpm)	Input Power (Watts)	Input Current (Amps)	Starting Current (Amps)	Weight (Kg/Lbs)	Noise (dB(A))	Drawing	Curve	Speed Signal	
											F.P.S	L.S.W
00000984	115V / 1 Phase / 400Hz	1	11300	30	0.4	1.5	0.32/0.7	73	Fig.1	Fig.A	-	-
00-85001578-0001	200V / 3 Phases / 400Hz	-	22000	120	0.4	1.5	0.32/0.7	88	Fig.2	Fig.B	√	-
00000983	115V / 3 Phases / 400Hz	-	22000	120	1.2	4	0.32/0.7	88	Fig.1	Fig.B	-	-

* Capacitor (not supplied) : 150 VAC

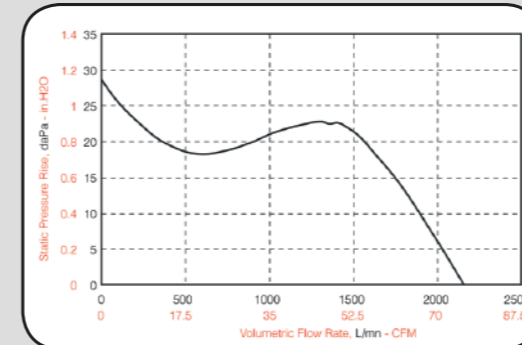

Fig.A

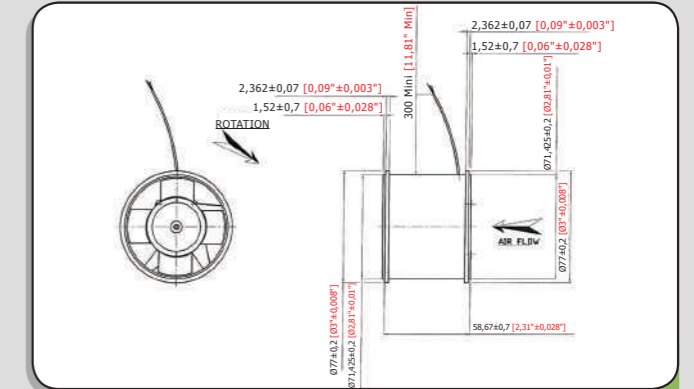

Fig.1

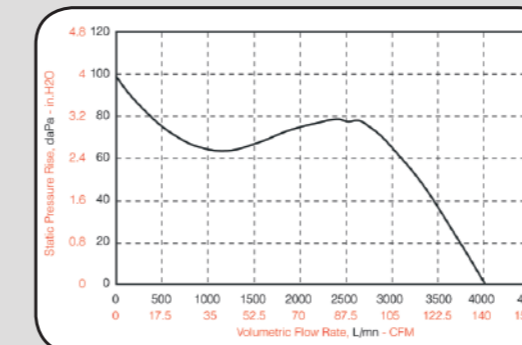

Fig.B

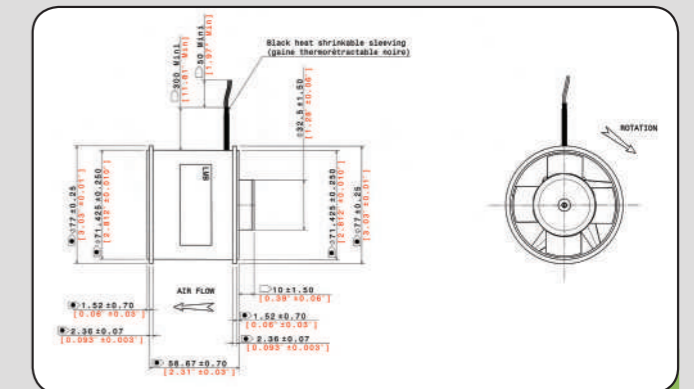

Fig.2

MELBA

Part Number	Power Supply	Cap (µF)	Speed (rpm)	Input Power (Watts)	Input Current (Amps)	Starting Current (Amps)	Weight (Kg/Lbs)	Noise (dB(A))	Drawing	Curve	Speed Signal	
											F.P.S	L.S.W
00000409	200V / 3 Phases / 400Hz	-	22250	240	0.8	4	0.758/1.65	100	Fig.1	Fig.A	-	-
00000959	115V / 3 Phases / 400Hz	-	22250	240	1.4	5	0.758/1.65	100	Fig.1	Fig.A	-	-

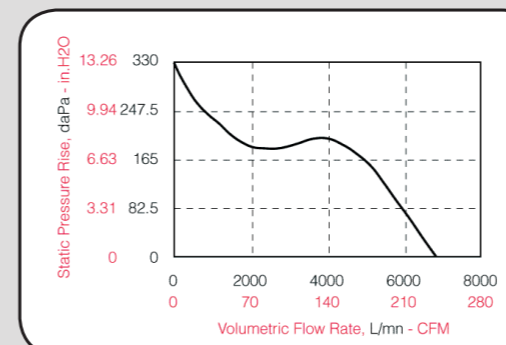

Fig.A

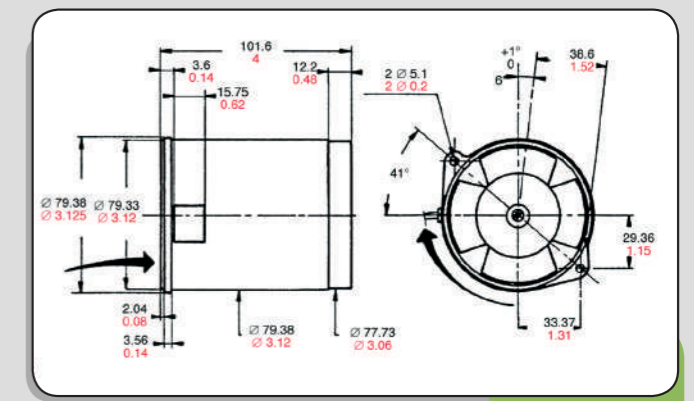

Fig.1

	Part Number	Power Supply	Cap* (µF)	Speed (rpm)	Input Power (Watts)	Input Current (Amps)	Starting Current (Amps)	Weight (Kg/Lbs)	Noise (dB(A))	Drawing	Curve	Speed Signal	
												F.P.S	L.S.W
PRODIGE	00000085	200V / 3 Phases / 400Hz	-	10500	38	0.14	0.43	0.32/0.70	76	Fig.1	Fig.A	-	-
	00000008	115V / 3 Phases / 400Hz	-	10500	38	0.25	0.75	0.32/0.70	76	Fig.1	Fig.A	-	-
PASTEUR	00000944	200V / 3 Phases / 400Hz	-	5600	11	0.07	0.14	0.35/0.77	64	Fig.2	Fig.B	-	-
	00000054	115V / 3 Phases / 400Hz	-	5600	11	1.2	2.5	0.35/0.77	64	Fig.2	Fig.B	-	-
PERSAN	00000630	200V / 3 Phases / 400Hz	-	7500	18	0.1	0.3	0.33/0.72	64	Fig.3	Fig.C	-	-
	00000125	115V / 1 Phase / 400Hz	0.56	7500	18	0.2	0.4	0.33/0.72	64	Fig.3	Fig.C	-	-
PENSEE	00000241	200V / 3 Phases / 400Hz	-	7500	73	0.35	1.3	0.62/1.35	82	Fig.4	Fig.D	-	-
	00000055	200V / 1 Phase / 400Hz	0.68	7500	78	0.42	1	0.62/1.35	82	Fig.4	Fig.D	-	-
PASTEL	00000457	200V / 3 Phases / 400Hz	-	5500	40	0.21	0.52	0.61/1.34	69	Fig.5	Fig.E	-	-
	00000896	115V / 1 Phase / 400Hz	1.2	5500	40	0.4	0.75	0.61/1.34	69	Fig.5	Fig.E	-	-

* Capacitor (not supplied) : 150 VAC

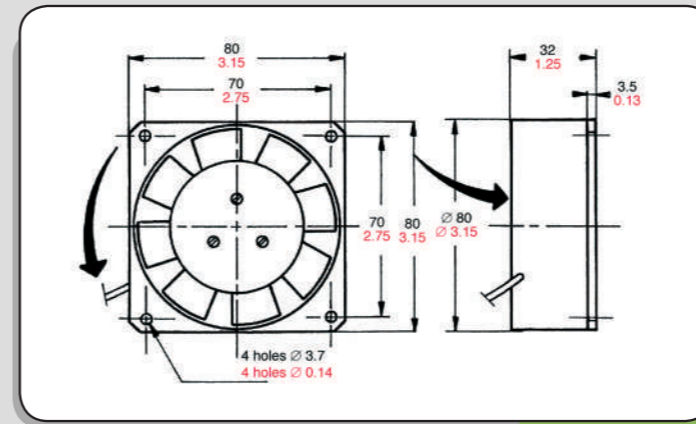

Fig.1

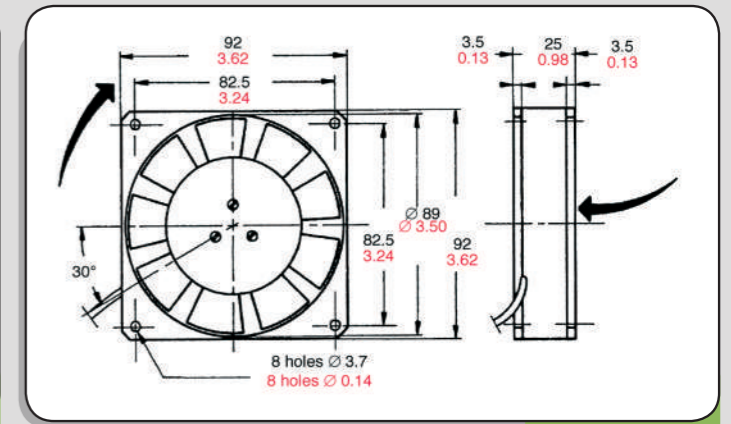

Fig.2

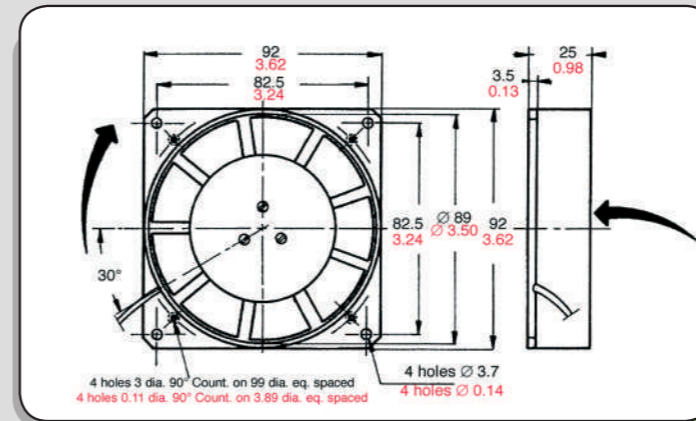

Fig.3

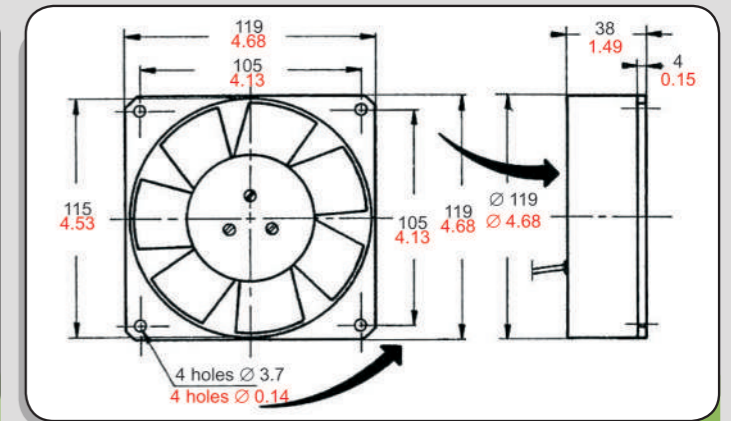

Fig.4

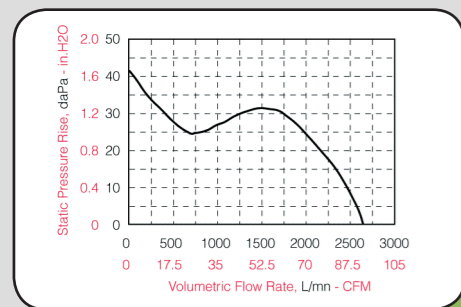

Fig.A

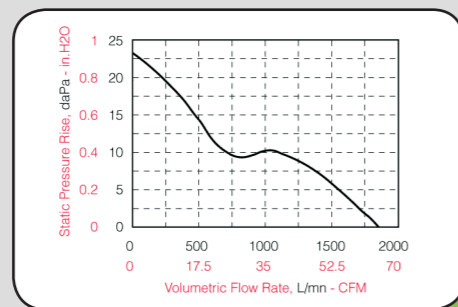

Fig.B

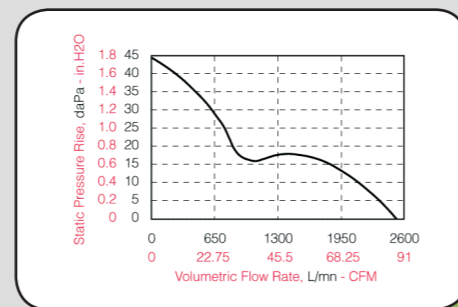

Fig.C

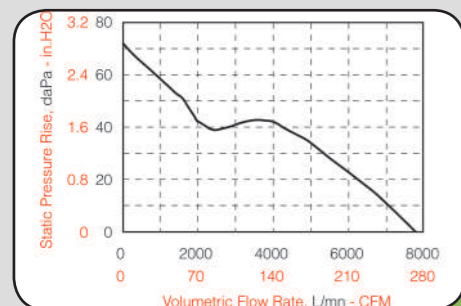

Fig.D

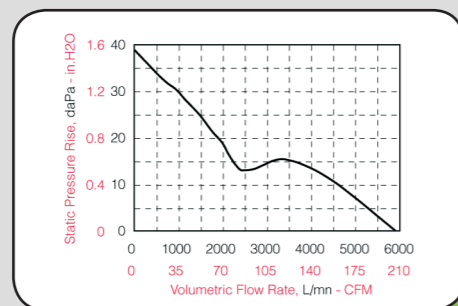

Fig.E

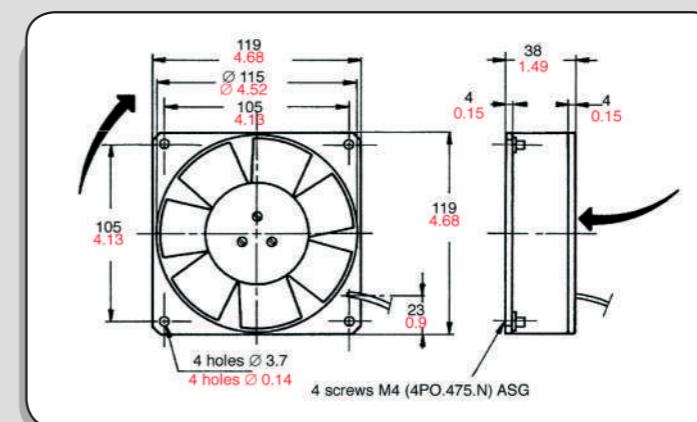

Fig.5

Part Number	Power Supply	Cap* (µF)	Speed (rpm)	Input Power (Watts)	Input Current (Amps)	Starting Current (Amps)	Weight (Kg/Lbs)	Noise (dB(A))	Drawing	Curve	Speed Signal F.P.S	L.S.W
00-85001506-001	115V / 1 Phase / 400Hz	2,2	3400	37	0,7	0,8	0,8 / 1,76	66	Fig.1	Fig.A	-	-
00-85001507-001	115V / 1 Phase / 400Hz	2,2	3400	37	0,7	0,8	0,8 / 1,76	66	Fig.2	Fig.A	-	-
00-85001443-001	115V / 1 Phase / 400Hz	2,2	3400	37	0,7	0,8	0,8 / 1,76	66	Fig.3	Fig.A	-	-
00-85001511-001	200V / 3 Phases / 400Hz	-	3400	43	0,4	0,62	0,8 / 1,76	66	Fig.1	Fig.A	-	-
00-85001512-001	200V / 3 Phases / 400Hz	-	3400	43	0,4	0,62	0,8 / 1,76	66	Fig.2	Fig.A	-	-
00-85001513-001	200V / 3 Phases / 400Hz	-	3400	43	0,4	0,62	0,8 / 1,76	66	Fig.3	Fig.A	-	-
00-85001514-001	200V / 3 Phases / 400Hz	-	5500	80	0,6	1,25	0,8 / 1,76	76	Fig.1	Fig.B	-	-
00-85001515-001	200V / 3 Phases / 400Hz	-	5500	80	0,6	1,25	0,8 / 1,76	76	Fig.2	Fig.B	-	-
00-85001516-001	200V / 3 Phases / 400Hz	-	5500	80	0,6	1,25	0,8 / 1,76	76	Fig.3	Fig.B	-	-

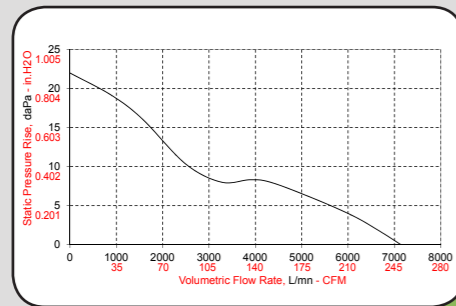

Fig.A

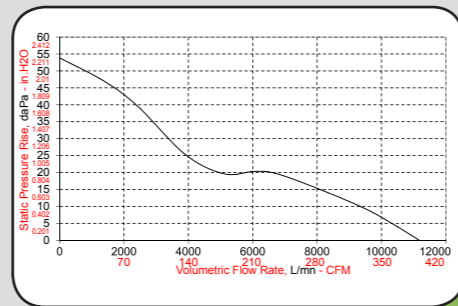

Fig.B

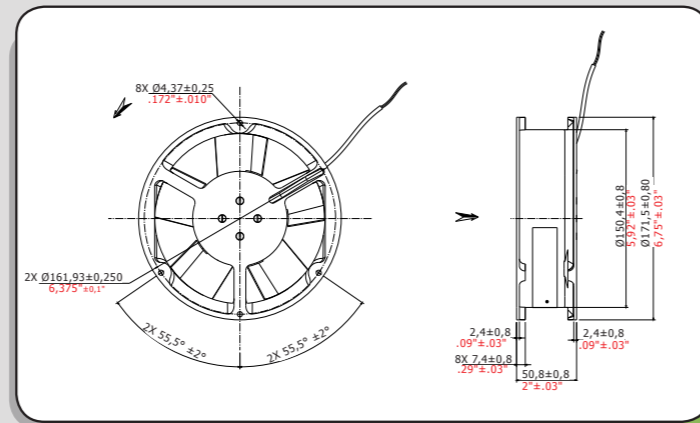

Fig.1

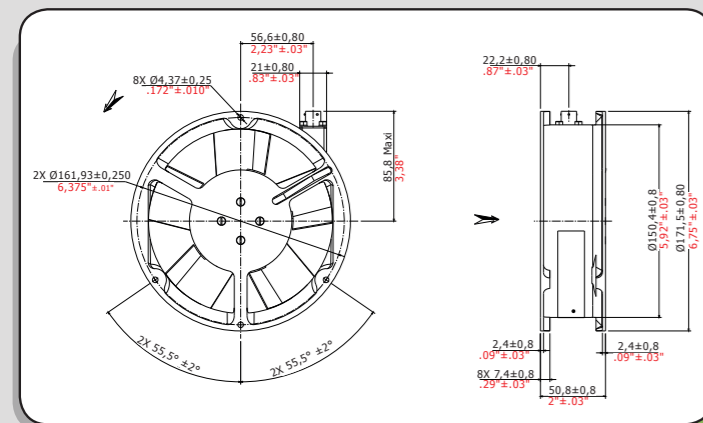

Fig.2

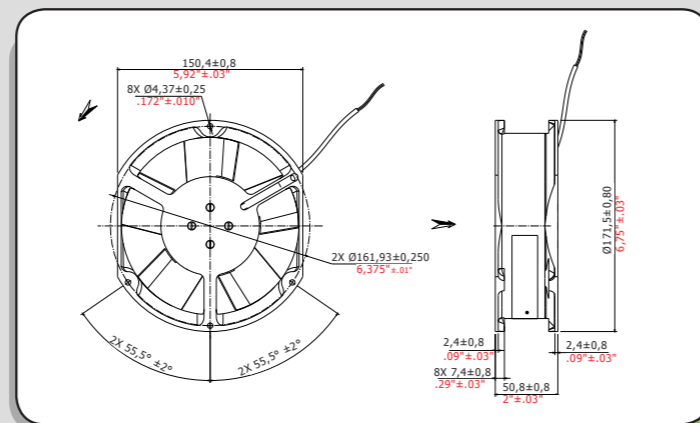

Fig.3

	Part Number	Power Supply	Cap** (µF)	Speed (rpm)	Input Power (Watts)	Input Current (Amps)	Starting Current (Amps)	Weight (Kg/Lbs)	Noise (dB(A))	Drawing	Curve	Speed Signal* F.P.S	L.S.W
MARATHON 4	00000939	200V / 3 Phases / 400Hz	-	11000	13	0.15	0.3	0.32/0.7	67	Fig.1	Fig.A	-	-
	00000940	115V / 1 Phase / 400Hz	1	11000	13	0.15	0.2	0.32/0.7	67	Fig.1	Fig.A	-	-
	00000206	115V / 3 Phases / 400Hz	-	11000	13	0.14	0.16	0.32/0.7	67	Fig.1	Fig.A	-	-
MARATHON 2	00000222	200V / 3 Phases / 400Hz	-	22000	78	0.28	1,4	0.32/0.7	82	Fig.1	Fig.B	-	-
	00000581	115V / 1 Phase / 400Hz	1	22000	97	0.8	1,6	0.32/0.7	82	Fig.1	Fig.B	-	-
	00000880	200V / 3 Phases / 400Hz	-	22000	78	0.28	1,4	0.37/0.82	82	Fig.2	Fig.B	✓	-
	00001256	115V / 1 Phase / 400Hz	1	22000	97	0.8	1,6	0.37/0.82	82	Fig.2	Fig.B	✓	-

* Refer to page 38 «speed signal» / ** Capacitor (not supplied) : 150 VAC

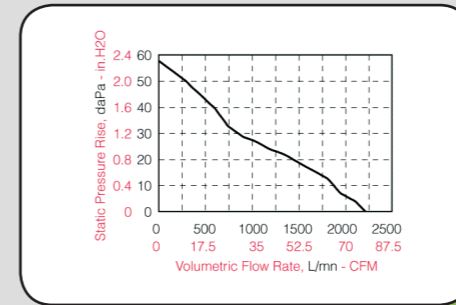

Fig.A

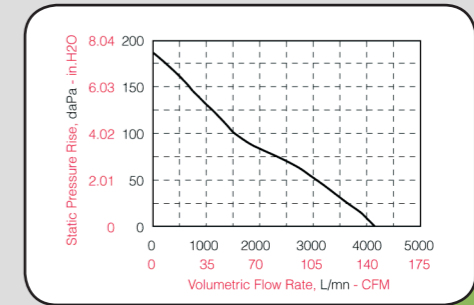

Fig.B

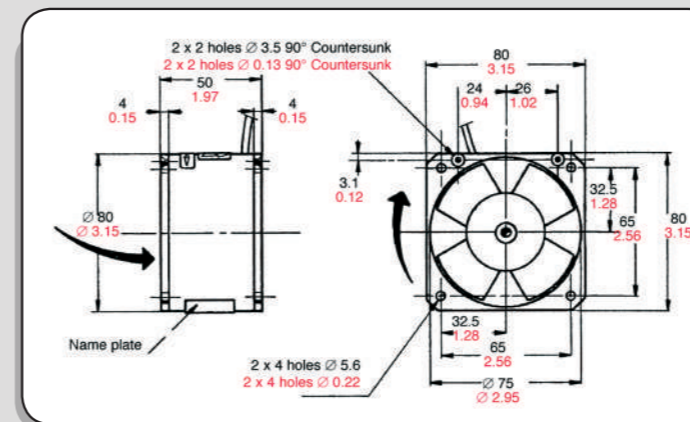

Fig.1

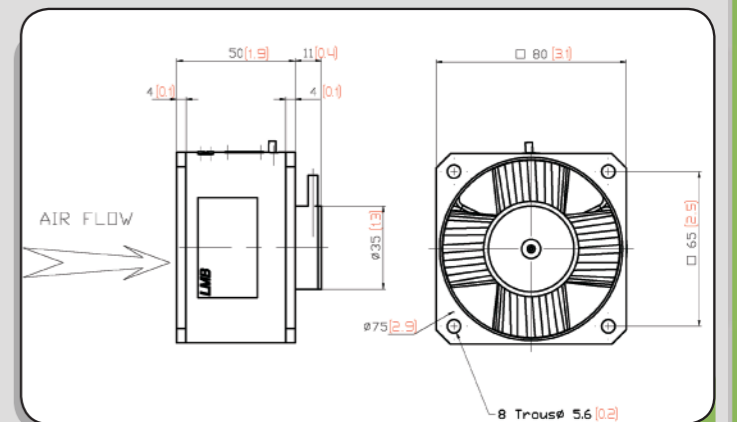

Fig.2

DESCRIPTION

In order to monitor and advise potential loss of cooling airflow, LMB AC & DC fans may incorporate warning and detection devices :

Fan Performance Sensor (FPS) provides a pulse output proportional to the fan speed.

Low Speed Warning (LSW) detects under-speed conditions and advises the system about airflow interruption.

This a logic signal (0 or 1).

FAN PERFORMANCE SENSOR FOR AC FANS

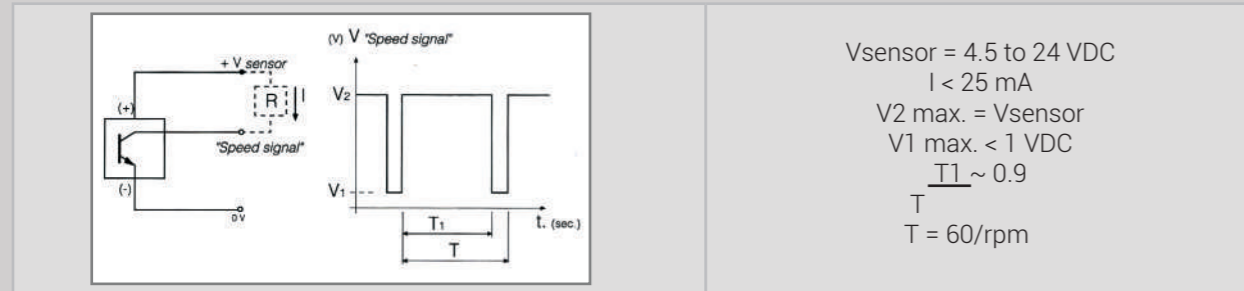

FAN PERFORMANCE SENSOR FOR DC BRUSHLESS FANS

Fan Performance Sensor

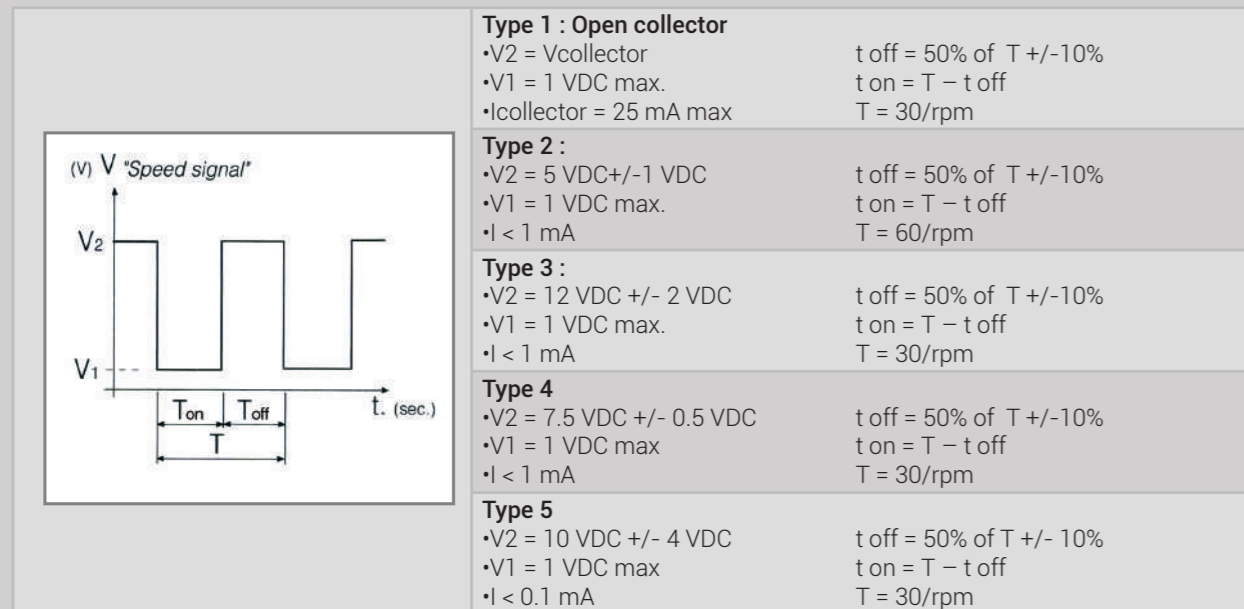

LOW SPEED WARNING :

- Physical description : - Connected by one wire : LSW.
- Return path by the "0 VDC" power input.

•Logic / electrical status :

Logic Status	Electrical state
NORMAL OPERATION	Grounded to 0 VDC
UNDERSPEED (Fail condition)	Open collector (external pull-up resistor)

The fan has to be electrically supplied to give proper information on the LSW output.

•Electrical characteristics :

Nominal output sink current @ 28VDC :
Current must be limited to 100 mA by an external pull-up resistor (not part of the fan),
Maximum output voltage in open collector state :
+28 VDC nominal ; +40 VDC surge with a pull-up resistor higher than 0,4KΩ.
Maximum output voltage when grounded to 0 VDC :
< 1,5 VDC.

•Detail operation:

LSW is unlatched.
During start-up LSW is not active (NORMAL_OPERATION) .

Wire	AWG	Color
+28VDC	#24	RED
0VDC	#24	BLACK
FPS	#24	BROWN
PWM INPUT	#24	BLUE

TEMPERATURE RANGE	
OPERATING	[-40, +85°C]
STORAGE	[-54°C, +105°C]

⁽¹⁾Standard conditions : 28vdc, free delivery, air density : 1.2 Kg/m³.
⁽²⁾ Average value
⁽³⁾ In case of defect, fan stops (latching).

ELECTRICAL INTERFACE			
POWER SUPPLY	28VDC NETWORK / 28VDC TYP, 32.2V MAX@5min / SURGE 48V@1s, 80V@100ms		
MIN. STARTING VOLTAGE	12V		
INPUT CURRENT	STEADY STATE	REFER TO LABEL ⁽¹⁾	
	STARTING CURRENT	2.3A TYP. ⁽²⁾	
INSULATION RESISTANCE	LEVEL	GROUP	VALUE
	50VDC	ALL WIRES LINKED TOGETHER / CASING	> 20MW
DIELECTRIC STRENGTH	500VDC		<1mA
PROTECTIONS	POWER LEADS	CROSS POLARITY	
	PWM	CONNEXION TO GROUND AND 28VDC (CONTINUOUS)	
	FAN	UNDERSPEED, ROTOR LOCKED ⁽³⁾	

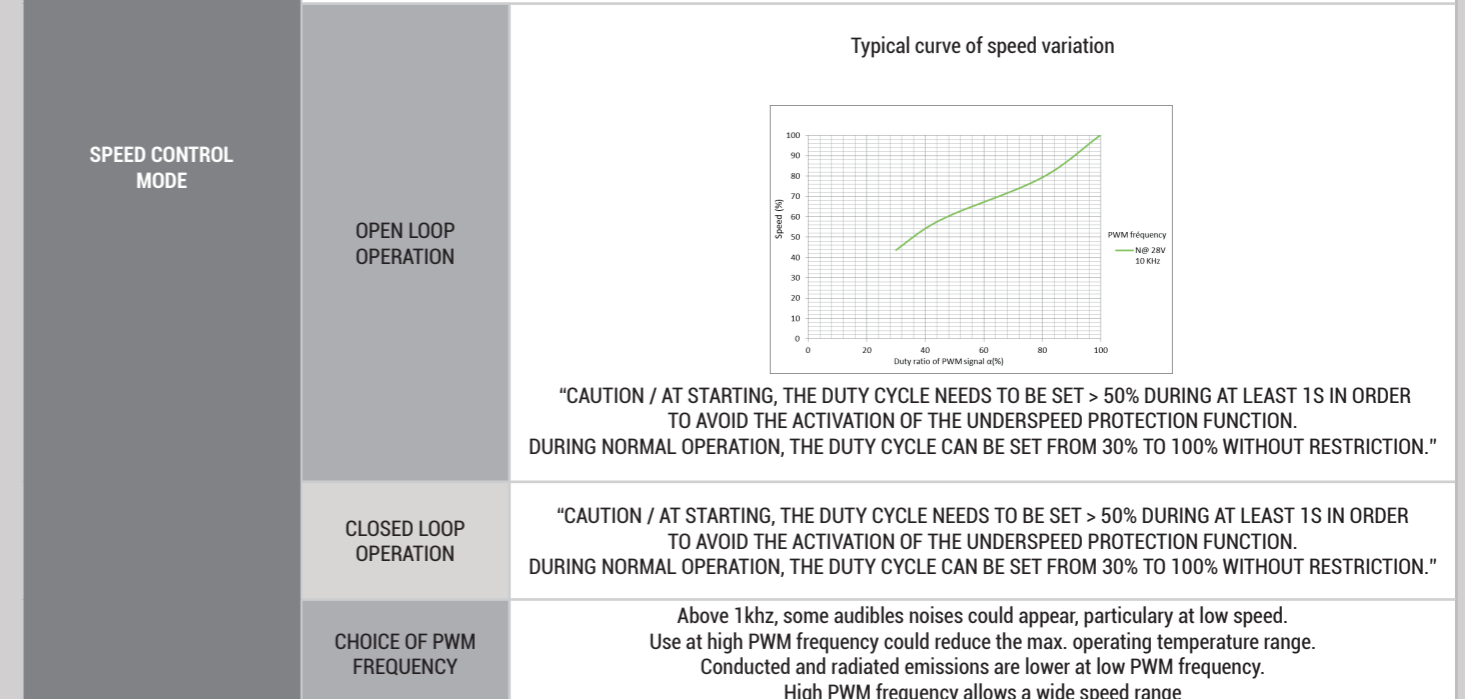
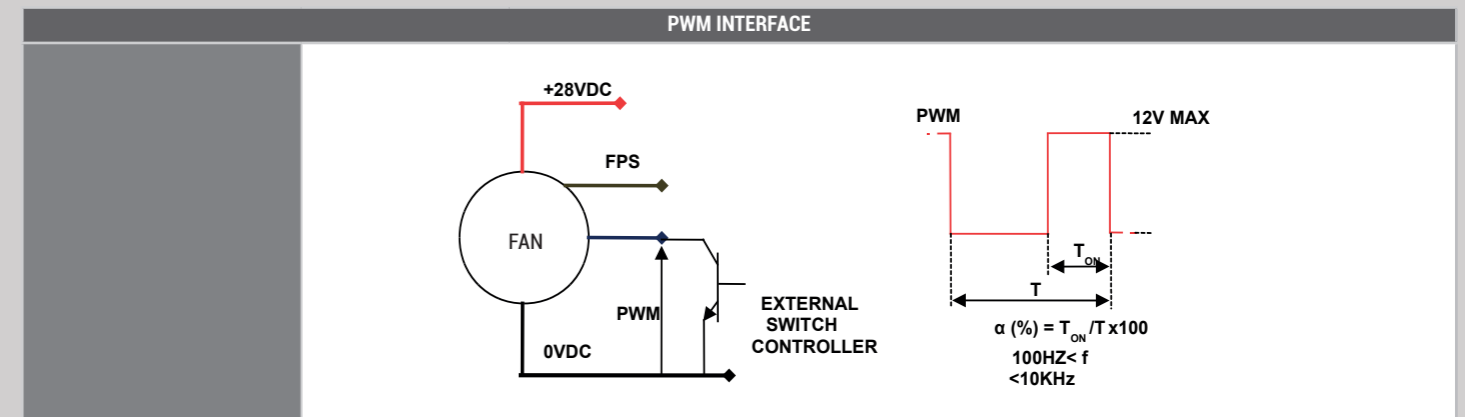
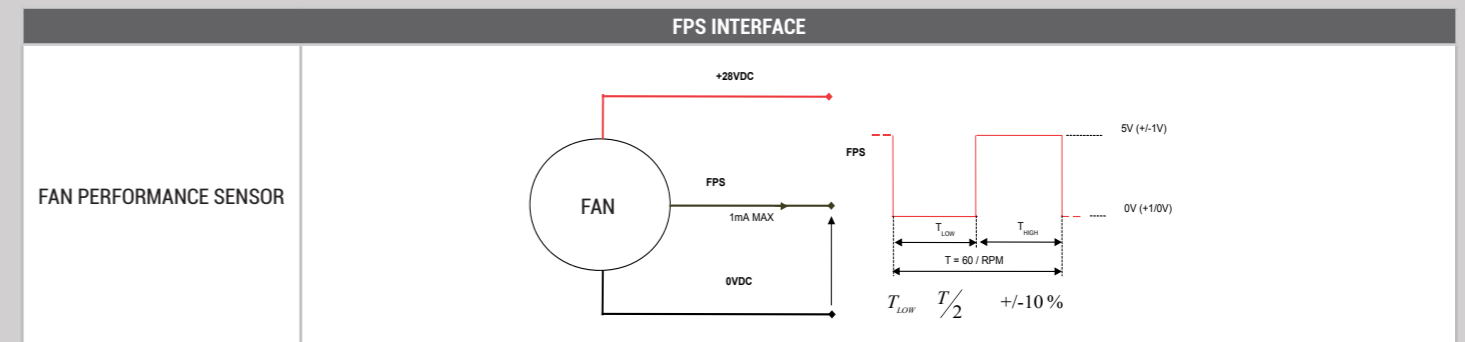

Wire	AWG	Color
+28VDC	#24	RED (rouge)
0VDC	#24	BLACK (noir)
0-5V speed command	#24	ORANGE (orange)
FPS	#24	BROWN (marron)

ELECTRICAL INTERFACE			
POWER SUPPLY	28VDC NETWORK / 28VDC TYP, 32.2V MAX@5min / SURGE 48V@1s, 80V@100ms		
MIN. STARTING VOLTAGE	12V		
INPUT CURRENT	STEADY STATE	REFER TO LABEL ⁽¹⁾	
	STARTING CURRENT	2.3A TYP. ⁽²⁾	
INSULATION RESISTANCE	LEVEL	GROUP	VALUE
	50VDC	ALL WIRES LINKED TOGETHER / CASING	> 20MΩ
PROTECTIONS	POWER LEADS	CROSS POLARITY	
	FPS	CONNEXION TO GROUND AND 28VDC (CONTINUOUS)	
	0-5V	IN CASE OF WIRE DISCONNECTION, THE FAN RUNS AT MAX. SPEED	
	FAN	UNDERSPEED, ROTOR LOCKED ⁽³⁾	

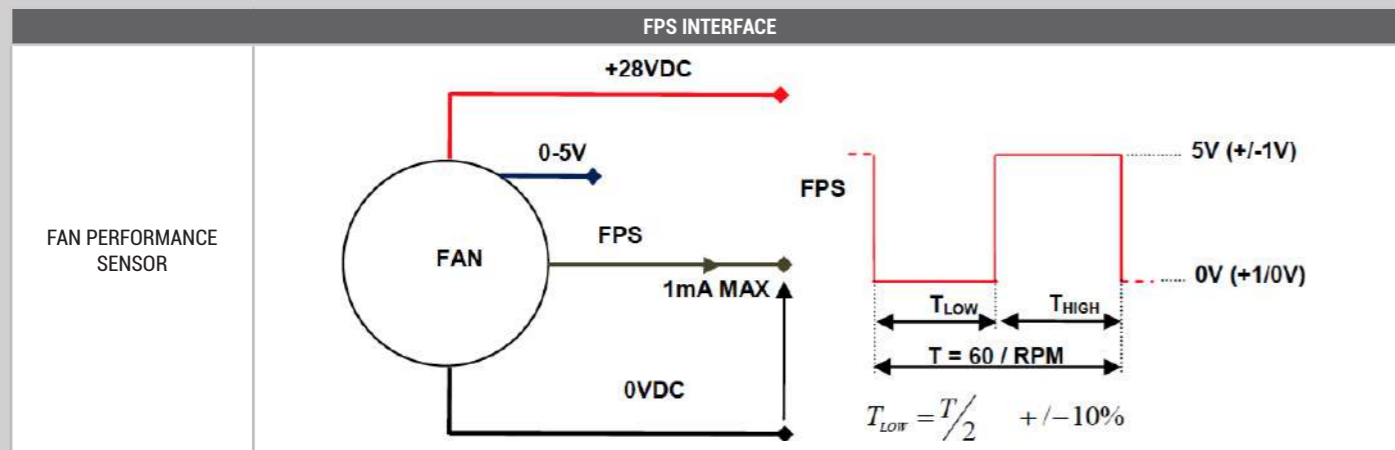

0-5VDC SPEED CONTROL INTERFACE

Max Voltage = 5.5V during 1mn
Max supply current = 1mA

SPEED CONTROL MODE

OPEN LOOP OPERATION

CLOSED LOOP OPERATION

TYPICAL CURVE OF SPEED VARIATION

CAUTION / DURING STARTING, TO DON'T TRIGGER UNDERSPEED PROTECTION, APPLY 2V DURING AT LEAST 1s

CAUTION / DURING STARTING, TO DON'T TRIGGER UNDERSPEED PROTECTION, APPLY 2V DURING AT LEAST 1s

TEMPERATURE RANGE	
OPERATING	[-40, +85°C]
STORAGE	[-54°C, +105°C]

⁽¹⁾Standard conditions : 28vdc, free delivery, air density : 1.2 Kg/m³.
⁽²⁾ Average value
⁽³⁾ In case of defect, fan stops (latching).

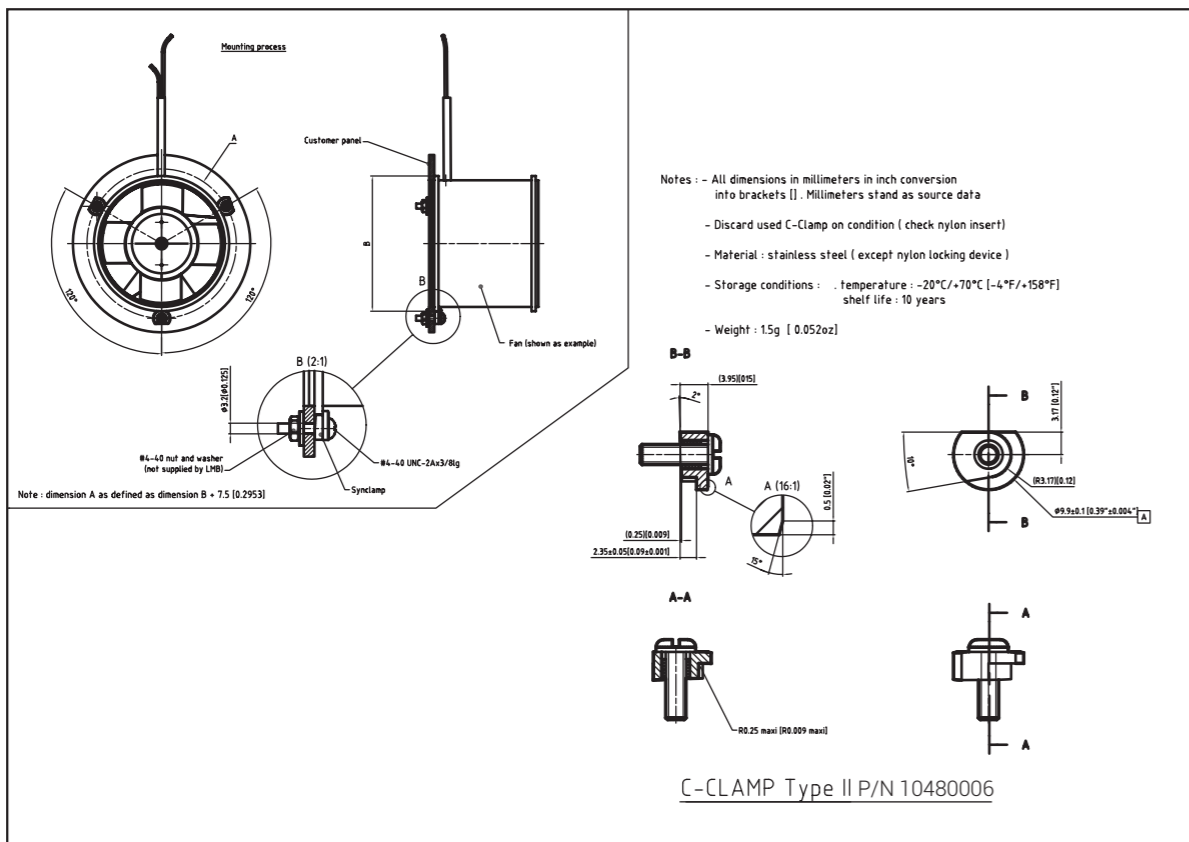
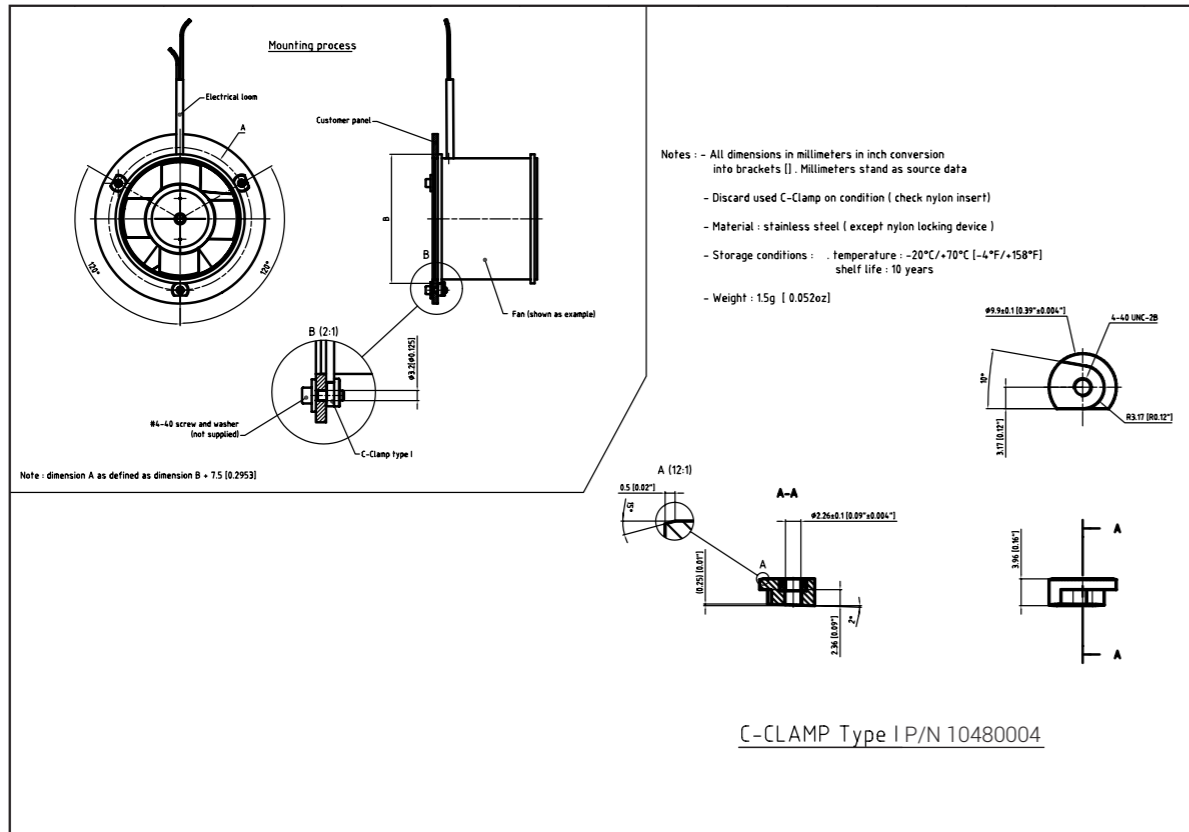

All finger guards are Stainless Steel (SS) unless otherwise noted.

PRODUCT FAMILY	PART NUMBER	INTERFACE	DRAWING
Optifan 44	10-85024824-001	Servo ring	Fig.1
Optifan 45	10-85024824-001	Servo ring	Fig.1
Optifan 65	10-85550030-001	Servo ring	Fig.2
Optifan 70	10-85550027-001	Servo ring	Fig.3
Optifan 70	10-85550038-001	Square flange - outlet side	Fig.4
Optifan 70	10-85550039-001	Square flange - inlet side	Fig.5
Optifan 75	10-85550028-001	Servo ring - inlet side	Fig.6
Optifan 75	10-85550031-001	Square flange	Fig.7
Optifan 75	10-85550032-001	Servo ring - outlet side	Fig.8
Pluton / Thinfan 120	10-85550036-001	Square flange	Fig.9
Thinfan 60	10-85550043-001	Square flange	Fig.10
Mouting kit*	10-85024668001	Servo ring	Fig.11

*Mounting kit includes : three washer P/N 10-85025065-001 and three nuts 10-85452026-001

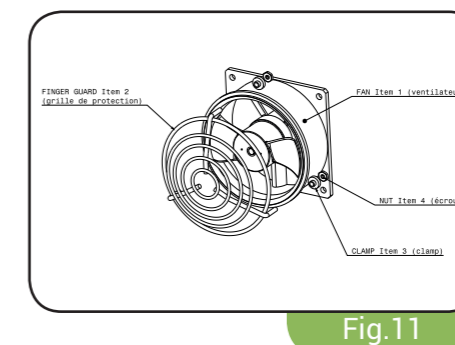
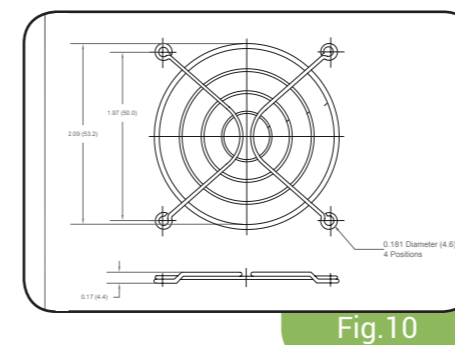
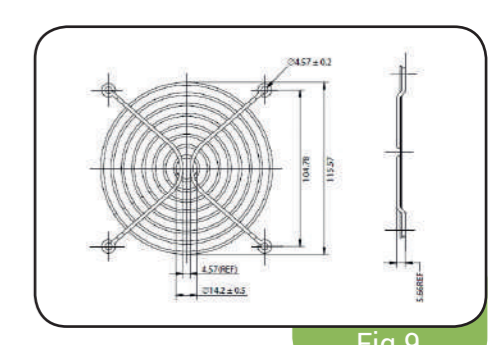
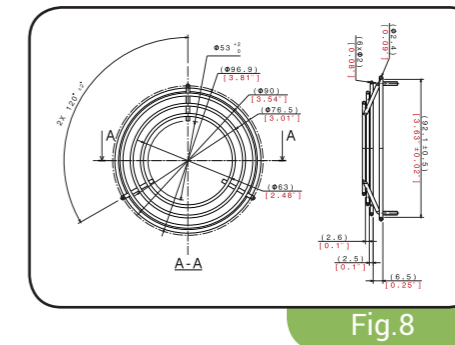
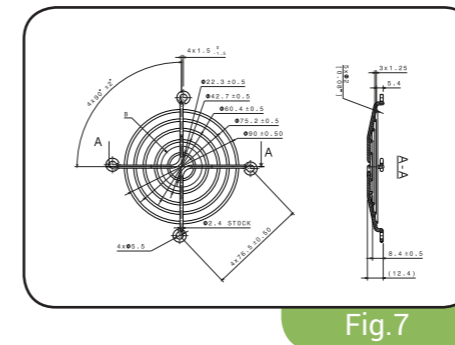
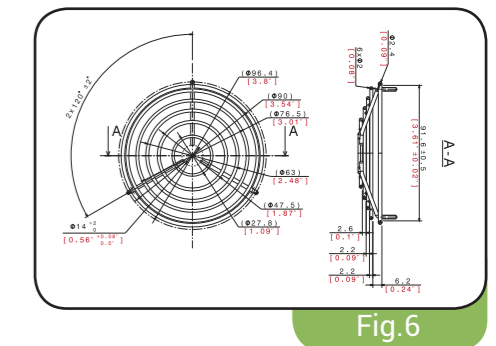
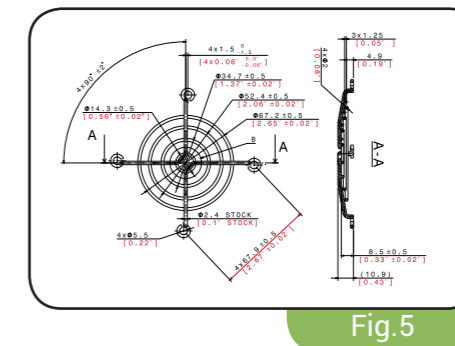
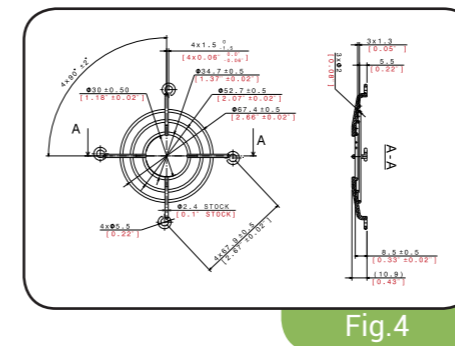
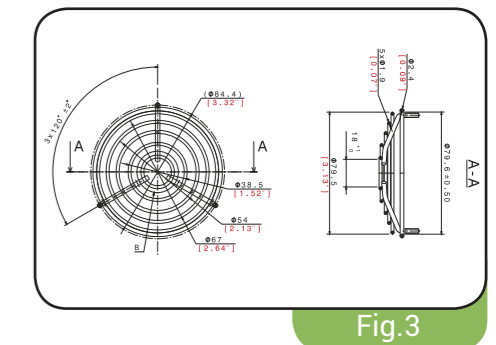
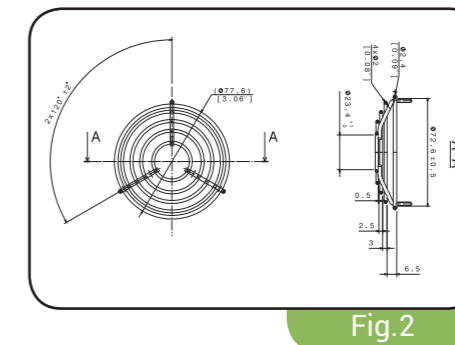
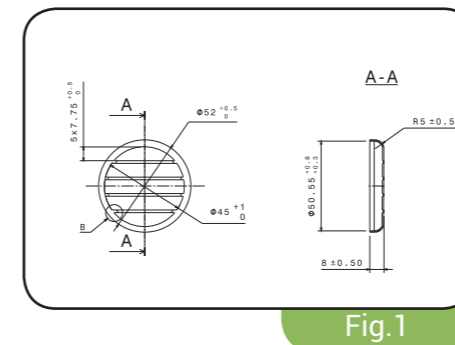



DENSITY

Standard air at 0.075 lbs/ft³ = 1.20 kg/m³

PRESSURE

- a. 1 centipieze = 1.02 mm H₂O
= 0.04 in H₂O
= 10Pa (Pascals)
= 0.1 millibar
- b. 1mm H₂O = 0.039 in H₂O
= 0.981 centipieze
= 9.8 Pa
= 4.02» H₂O
- c.1 Kpa = 102 mmH₂O
= 100 centipiezes
= 4.02" H₂O
= 10 millibars
- d.1 millibar = 10.2 mm H₂O
= 0.40 in H₂O
= 100 Pa
= 10 centipiezes
- e. 1 Inch H₂O = 25.4 mm H₂O
= 249 Pa
= 2.49 millibars
= 24.9 centipiezes

AIR FLOW

- a. 1 l per min = 0.017 l/s
= 0.035 cfm
= 0.06 m³/h
- b. 1 l/s = 60 l/min
= 2.12 cfm
= 3.6 m³/h
- c. 1 cfm = 0.47 l/s
= 28.3 l/min
= 1.7 m³/h
- d. 1 m³/h = 0.28 l/s
= 16.7 l/mn
= 0.59 cfm

TEMPERATURE

- T° (°K) = T° (°C) + 273.15
- T° (°C) = (T° (°F) - 32) : 1.8
- T° (°F) = T° (°C) x 1.8 + 32

LENGTHS

- 1 inch = 25.4 mm (2.54 cm)
- 1 mm = 0.039"
- 1 cm = 0.394"

WEIGHT

- 1 g = 0.035 oz
- 1 kg = 2.204 lbs



**OUR MISSION IS
TO PROVIDE YOU
THE SOLUTIONS
YOU CANNOT FIND ANYWHERE ELSE**



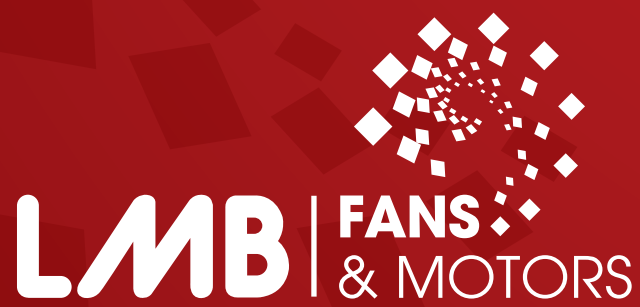

www.lmbaerospace.com

36 , avenue Marie & Pierre Curie 19360 MALEMORT - FRANCE
+33 (0)5 55 92 16 33 - +33 (0)5 55 92 19 00
lmbsales@lmbaerospace.com